



**AZOL-GAS**

CUÑAS Y CARROS  
WEDGE AND ROLLER CAM UNITS

**Boa**

# CUÑAS NCX NCX CAM UNITS

## ÁNGULOS MÁXIMOS ADMISIBLES / MAXIMUM ANGLES

### NCX-R

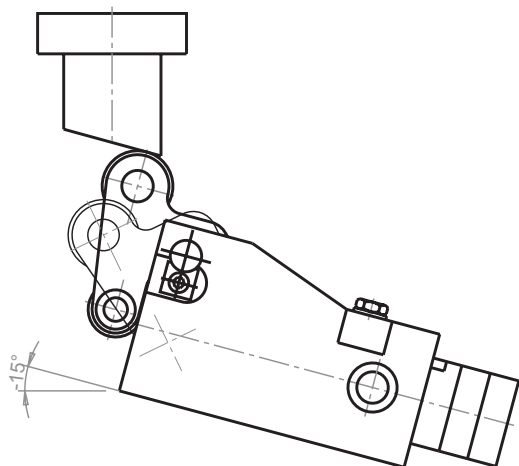

$-15^{\circ}$

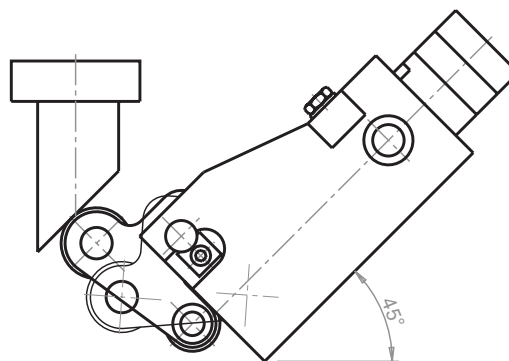

$45^{\circ}$

### NCX-R 45

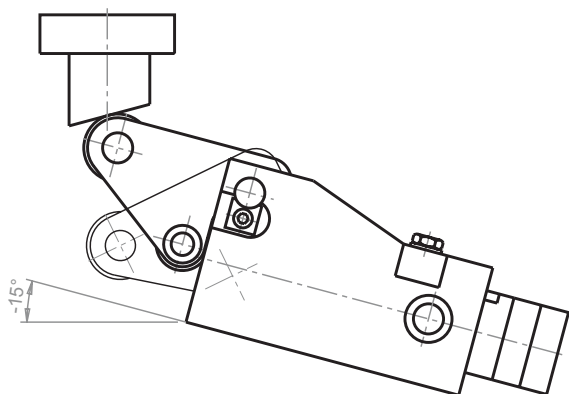

$-15^{\circ}$

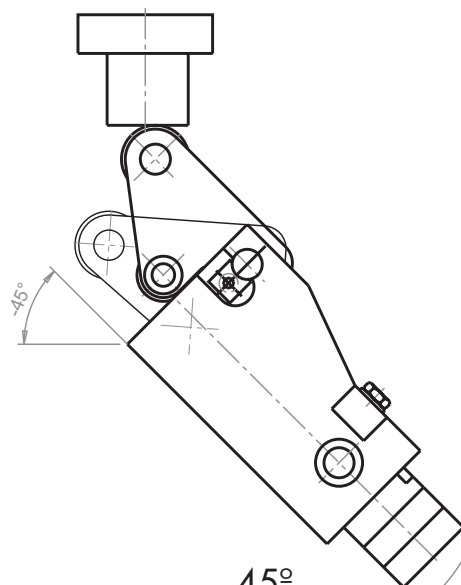

$-45^{\circ}$

Se recomienda una reserva del 10% de la carrera.  
Azol-Gas se reserva el derecho a efectuar cambios de diseño.

A 10% stroke length allowance is recommended.  
Azol-Gas keeps its right to make any desing modification.



# INDICE DE CARROS

## ROLLER CAMS INDEX

MODELO MODEL	PAGINA PAGE	FUERZA Max. DE CORTE CUTTING Max. FORCE (daN.)
<b>NCX - R - 089</b>	1	3000
<b>NCX - R - 159</b>	2	5000
<b>NCX ( NCT ) - R - 199</b>	3	7000
<b>NCX ( NCT ) - R - 320</b>	4	10000
<b>NCX - S - 089</b>	5	3000
<b>NCX - S - 159</b>	6	5000
<b>NCX - S - 199</b>	7	7000
<b>NCX - S - 320</b>	8	10000
<b>NCX - R45 - 089</b>	9	3000
<b>NCX - R45 - 159</b>	10	5000
<b>NCX ( NCT ) - R45 - 199</b>	11	7000
<b>NCX ( NCT ) - R45 - 320</b>	12	10000
<b>RECAMBIOS / SPARE PARTS</b>	13	---
<b>SOPORTE / DRIVERS</b>	14	---
<b>EJEMPLOS / EXAMPLES</b>	15 - 16	---
<b>SX - SXO - LX - LXO</b>	17 - 18	1500 - 25000
<b>CX</b>	19	1000 - 18000
<b>ECX - 03</b>	21	3000
<b>ECX - 05</b>	22	5000
<b>SOPORTES OCX / OCX DRIVERS</b>	23	---
<b>OCX ( OCT ) - 03</b>	24	3000
<b>OCX ( OCT ) - 05</b>	25	5000
<b>OCX ( OCT ) - 15</b>	26	15000
<b>OCX ( OCT ) - 20</b>	27	20000
<b>UCX - 05</b>	28	5000
<b>UCX - 15</b>	29	15000
<b>UCX - 20</b>	30	20000
<b>RCX - 03</b>	31	3000
<b>RCX - 05</b>	32	5000
<b>RCX - 15</b>	33	15000
<b>RCX - 20</b>	34	20000
<b>UCK - 05</b>	35	5000
<b>UCK - 08</b>	36	8000
<b>UCK - 20</b>	37	20000
<b>UCX - E - 03</b>	38	3000
<b>UCX - E - 05</b>	39	5000
<b>UCX - E - 07</b>	40	7000
<b>UCX - E - 15</b>	41	15000
<b>GCX - 03</b>	42	3000
<b>GCX - 05</b>	43	5000

# CUÑA NCX - R - 089

## NCX - R - 089 CAM UNIT

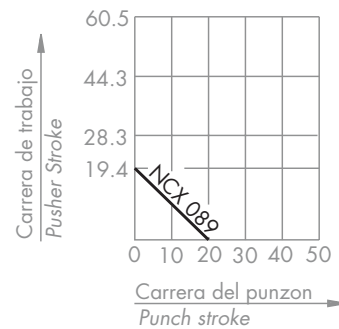
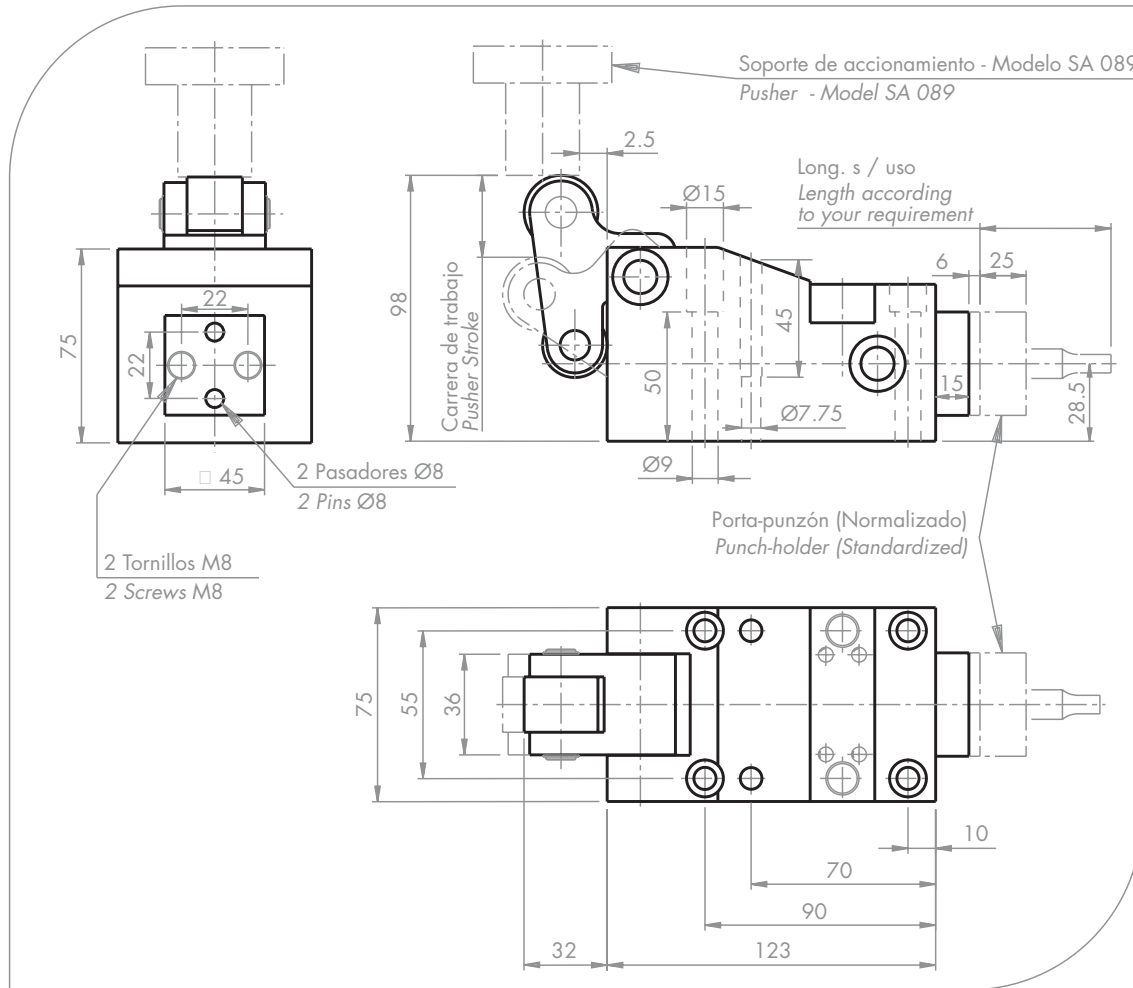

Carrera máx. (mm.) Stroke max.	Fuerza de retroceso (daN) Backward force	Diámetro máx. de punzón (mm.) Max. punch diameter	Fuerza máx. de corte (daN) Cutting max. force
20	150	10	3000

### EJEMPLO DE PEDIDO / ORDER EXAMPLE

NCX - R - 089

Modelo  
Model

Tipo  
Type

Se recomienda una reserva del 10% de la carrera.  
Azol-Gas se reserva el derecho a efectuar cambios de diseño.

A 10% stroke length allowance is recommended.  
Azol-Gas keeps its right to make any desing modification.

# CUÑA NCX - R - 159

## NCX - R - 159 CAM UNIT

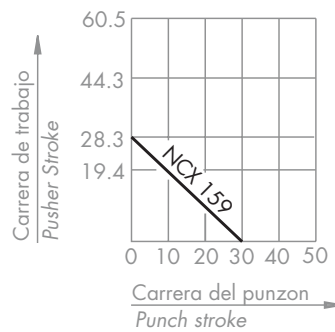
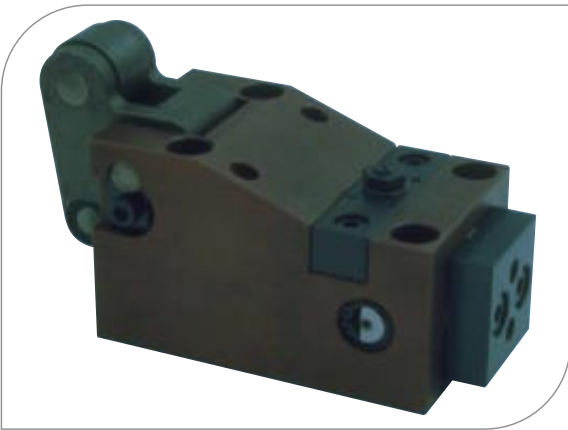
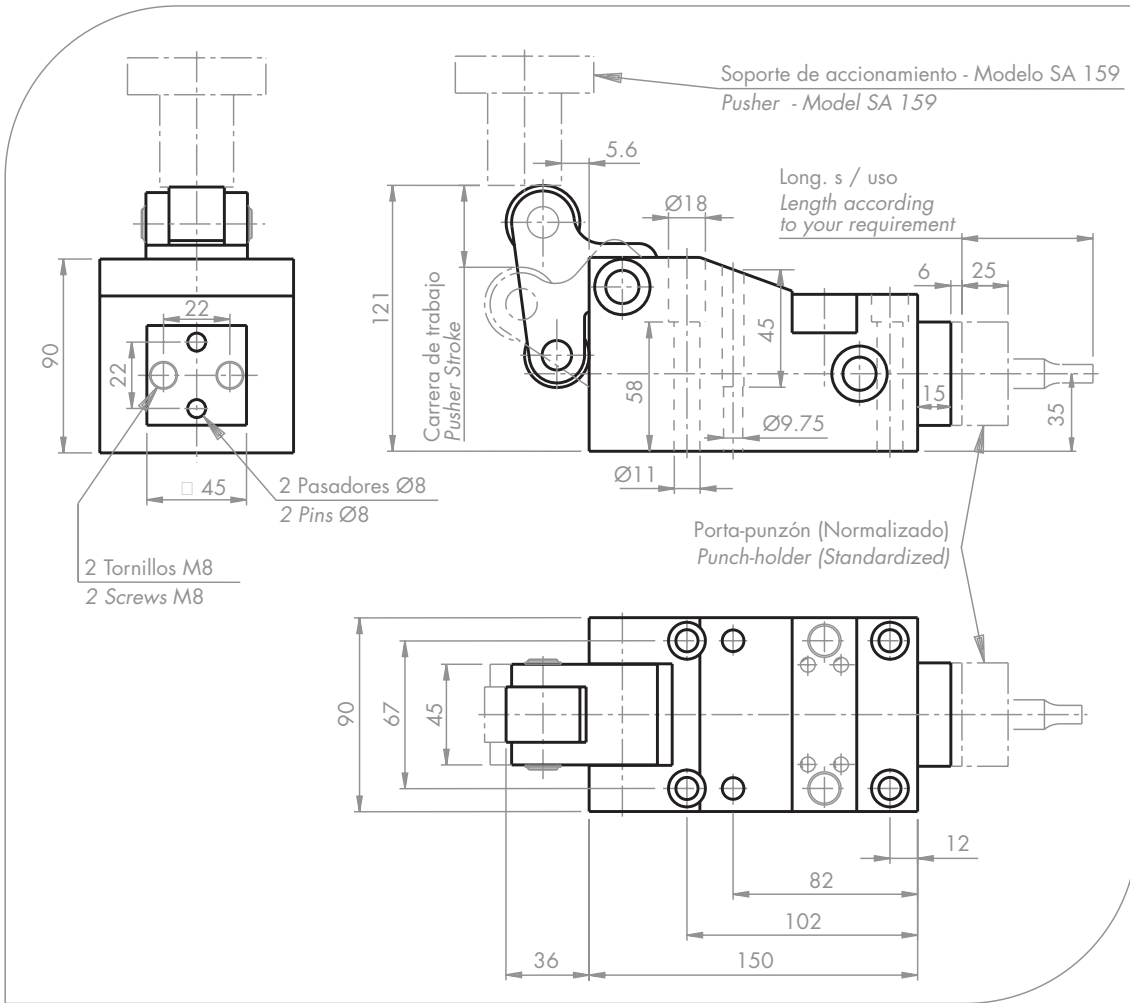

Carrera máx. (mm.) Stroke max.	Fuerza de retroceso (daN) Backward force	Diámetro máx. de punzón (mm.) Max. punch diameter	Fuerza máx. de corte (daN) Cutting max. force
30	200	16	5000

### EJEMPLO DE PEDIDO / ORDER EXAMPLE

NCX - R - 159

Modelo  
Model

Tipo  
Type

Se recomienda una reserva del 10% de la carrera.  
Azol-Gas se reserva el derecho a efectuar cambios de diseño.

A 10% stroke length allowance is recommended.  
Azol-Gas keeps its right to make any desing modification.

# CUÑA NCX ( NCT ) - R - 199

## NCX ( NCT ) - R - 199 CAM UNIT

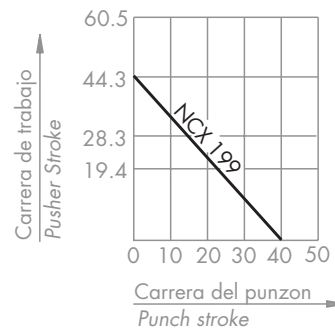
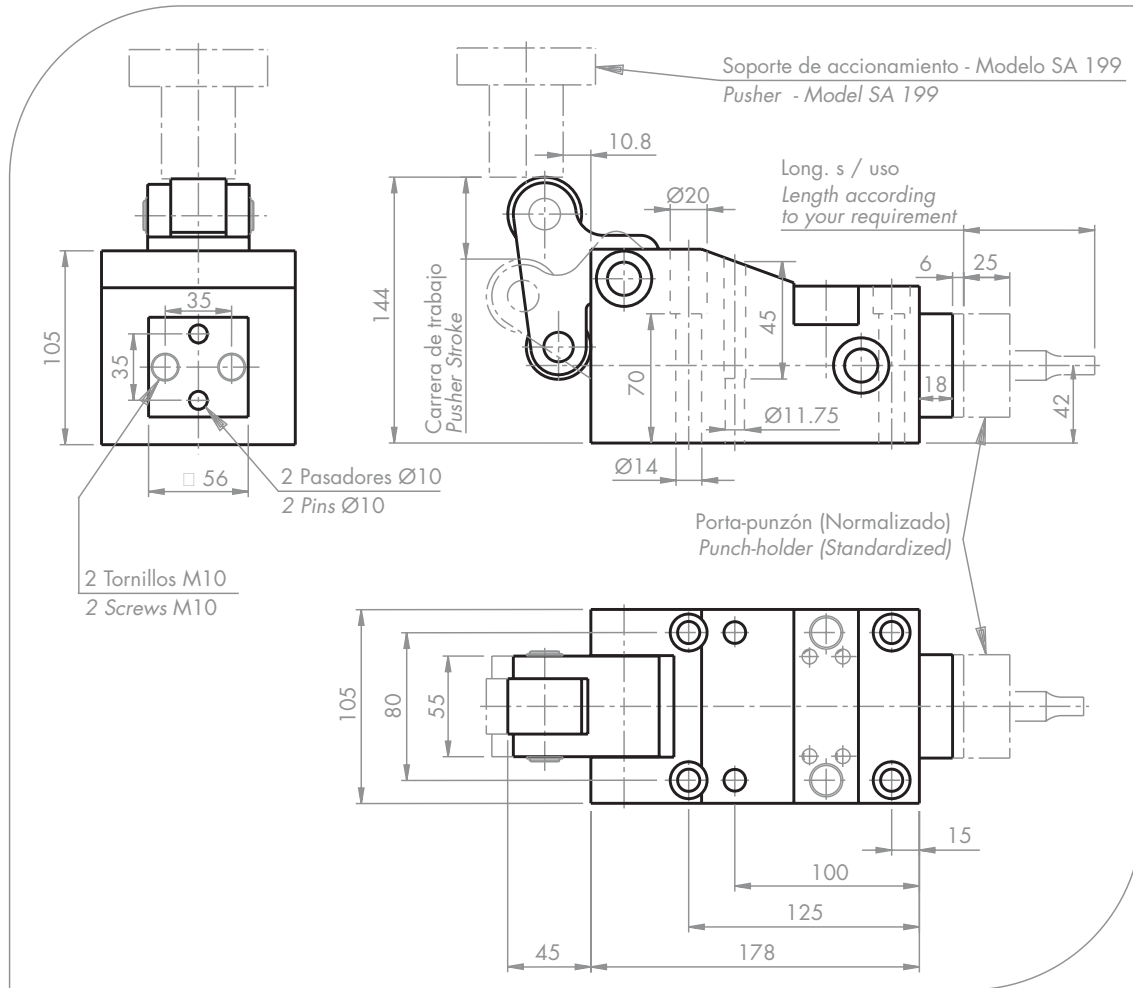

Carrera máx. (mm.) Stroke max.	Fuerza de retroceso (daN) Backward force	Diámetro máx. de punzón (mm.) Max. punch diameter	Fuerza máx. de corte (daN) Cutting max. force
40	250 NCX / NCT 500	20	7000

### EJEMPLO DE PEDIDO / ORDER EXAMPLE

NCX - R - 199

Modelo  
Model

Tipo  
Type

Se recomienda una reserva del 10% de la carrera.  
Azol-Gas se reserva el derecho a efectuar cambios de diseño.

A 10% stroke length allowance is recommended.  
Azol-Gas keeps its right to make any desing modification.

# CUÑA NCX ( NCT ) - R - 320

## NCX ( NCT ) - R - 320 CAM UNIT

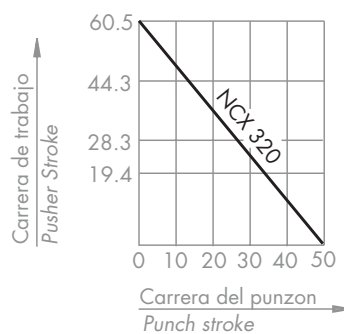
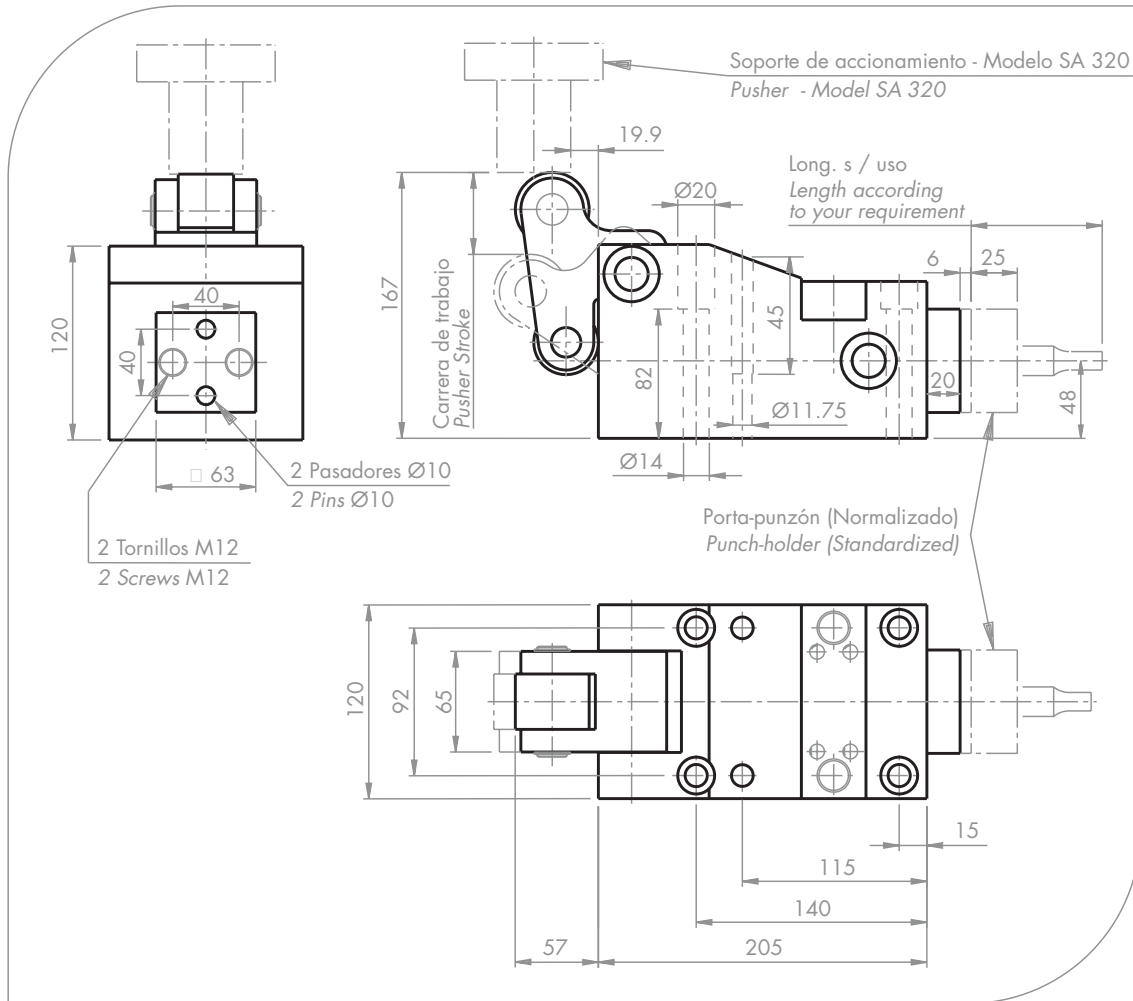

Carrera máx. (mm.) Stroke max.	Fuerza de retroceso (daN) Backward force	Diámetro máx. de punzón (mm.) Max. punch diameter	Fuerza máx. de corte (daN) Cutting max. force
50	500 <sub>NCX</sub> / 750 <sub>NCT</sub>	25	10000

### EJEMPLO DE PEDIDO / ORDER EXAMPLE

NCX - R - 320

Modelo  
Model

Tipo  
Type

Se recomienda una reserva del 10% de la carrera.  
Azol-Gas se reserva el derecho a efectuar cambios de diseño.

A 10% stroke length allowance is recommended.  
Azol-Gas keeps its right to make any desing modification.

# CUÑA NCX - S - 089

## NCX - S - 089 CAM UNIT

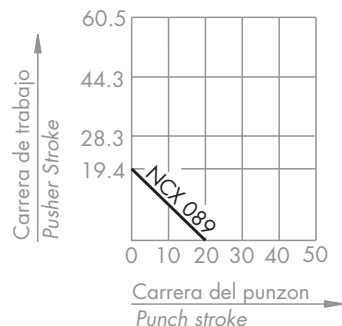
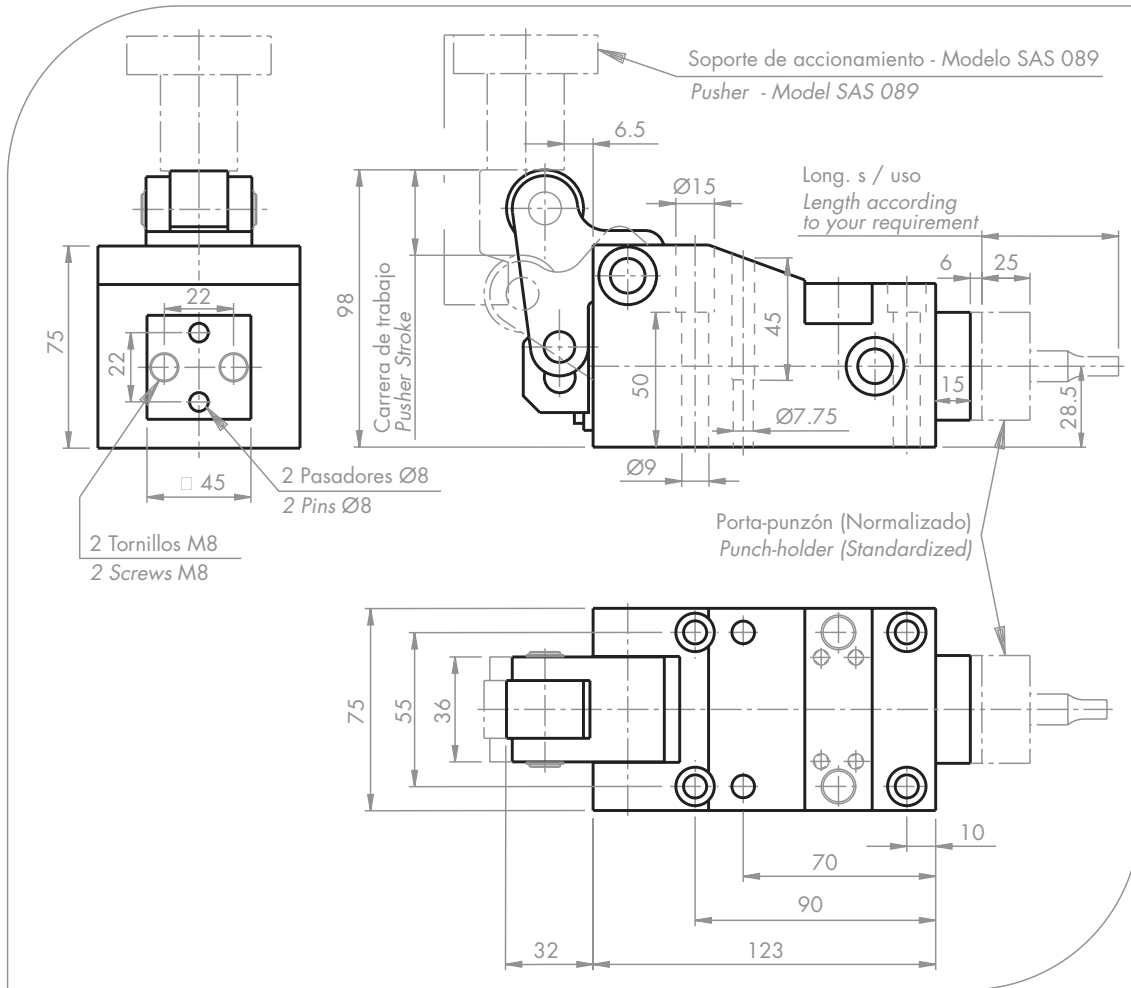

Carrera máx. (mm.) Stroke max.	Fuerza de retroceso (daN) Backward force	Diámetro máx. de punzón (mm.) Max. punch diameter	Fuerza máx. de corte (daN) Cutting max. force
20	150	10	3000

### EJEMPLO DE PEDIDO / ORDER EXAMPLE

NCX - S - 089

Modelo  
Model

Tipo  
Type

Se recomienda una reserva del 10% de la carrera.  
Azol-Gas se reserva el derecho a efectuar cambios de diseño.

A 10% stroke length allowance is recommended.  
Azol-Gas keeps its right to make any desing modification.



# CUÑA NCX - S - 159

## NCX - S - 159 CAM UNIT

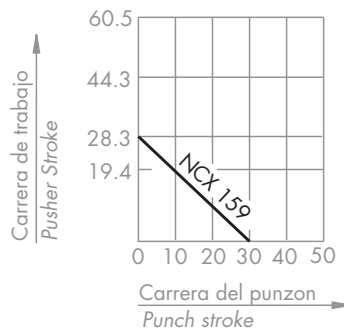
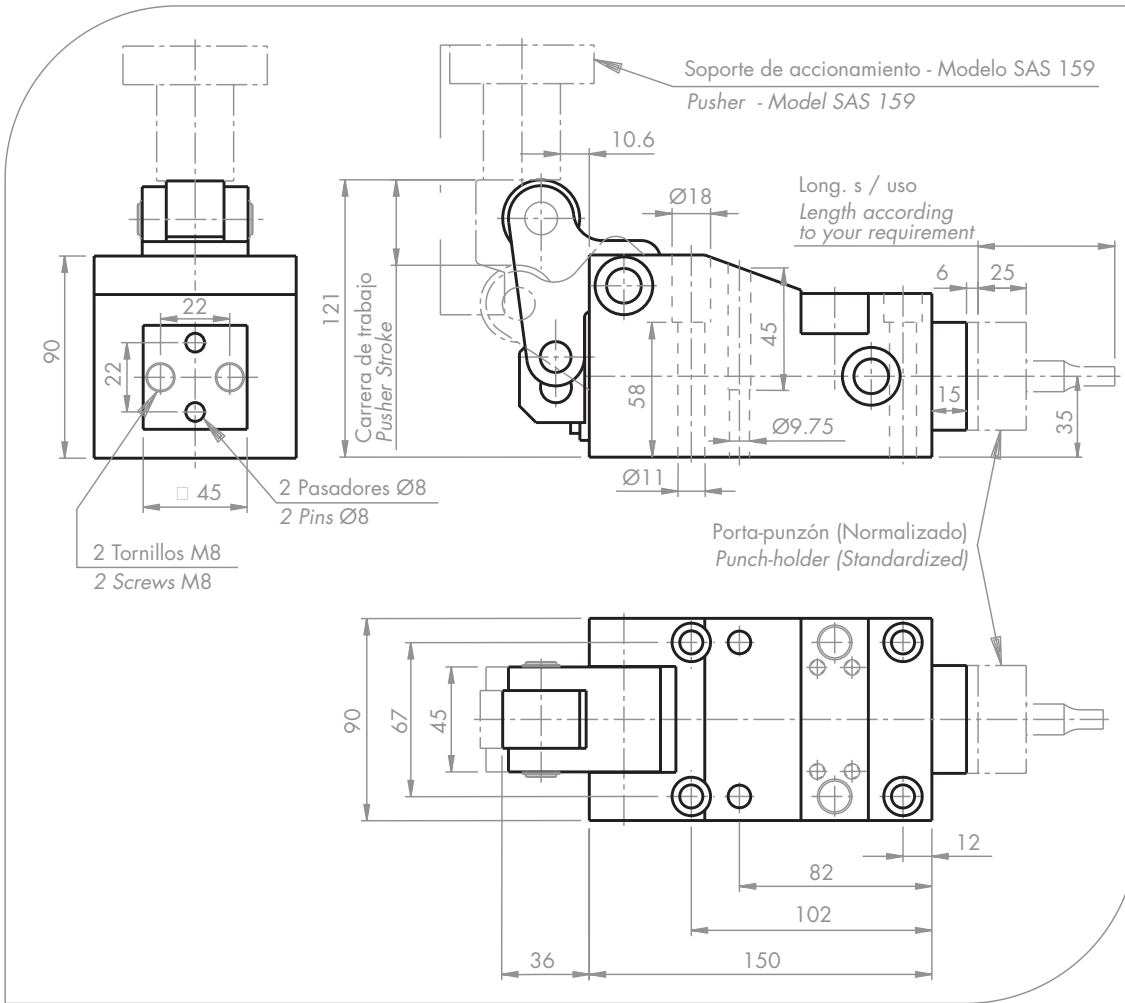

Carrera máx. (mm.) Stroke max.	Fuerza de retroceso (daN) Backward force	Diámetro máx. de punzón (mm.) Max. punch diameter	Fuerza máx. de corte (daN) Cutting max. force
30	200	16	5000

### EJEMPLO DE PEDIDO / ORDER EXAMPLE

NCX - S - 159

Modelo  
Model

Tipo  
Type

Se recomienda una reserva del 10% de la carrera.  
Azol-Gas se reserva el derecho a efectuar cambios de diseño.

A 10% stroke length allowance is recommended.  
Azol-Gas keeps its right to make any desing modification.

# CUÑA NCX ( NCT ) - S - 199

## NCX ( NCT ) - S - 199 CAM UNIT

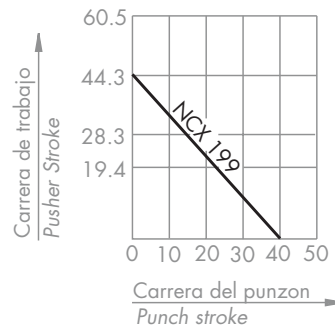
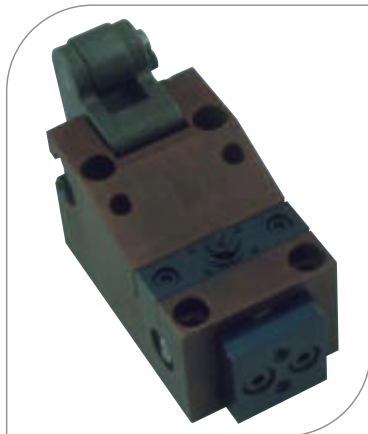
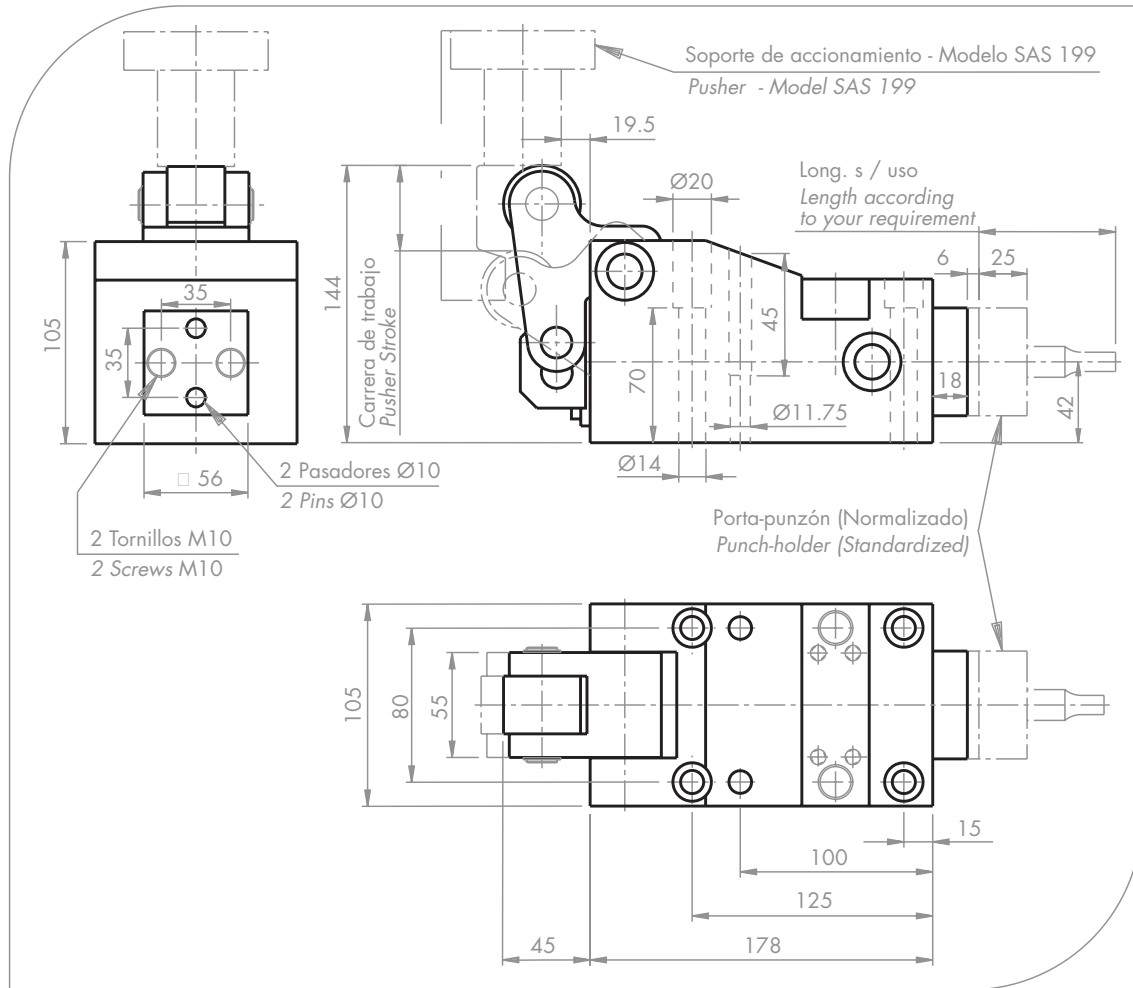

Carrera máx. (mm.) Stroke max.	Fuerza de retroceso (daN) Backward force	Diámetro máx. de punzón (mm.) Max. punch diameter	Fuerza máx. de corte (daN) Cutting max. force
40	250 NCX NCT 500	20	7000

### EJEMPLO DE PEDIDO / ORDER EXAMPLE

NCX - S - 199

Modelo  
Model

Tipo  
Type

Se recomienda una reserva del 10% de la carrera.  
Azol-Gas se reserva el derecho a efectuar cambios de diseño.

A 10% stroke length allowance is recommended.  
Azol-Gas keeps its right to make any desing modification.

# CUÑA NCX ( NCT ) - S - 320

## NCX ( NCT ) - S - 320 CAM UNIT

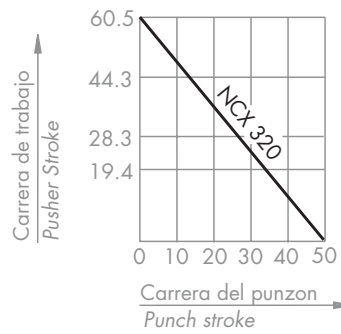
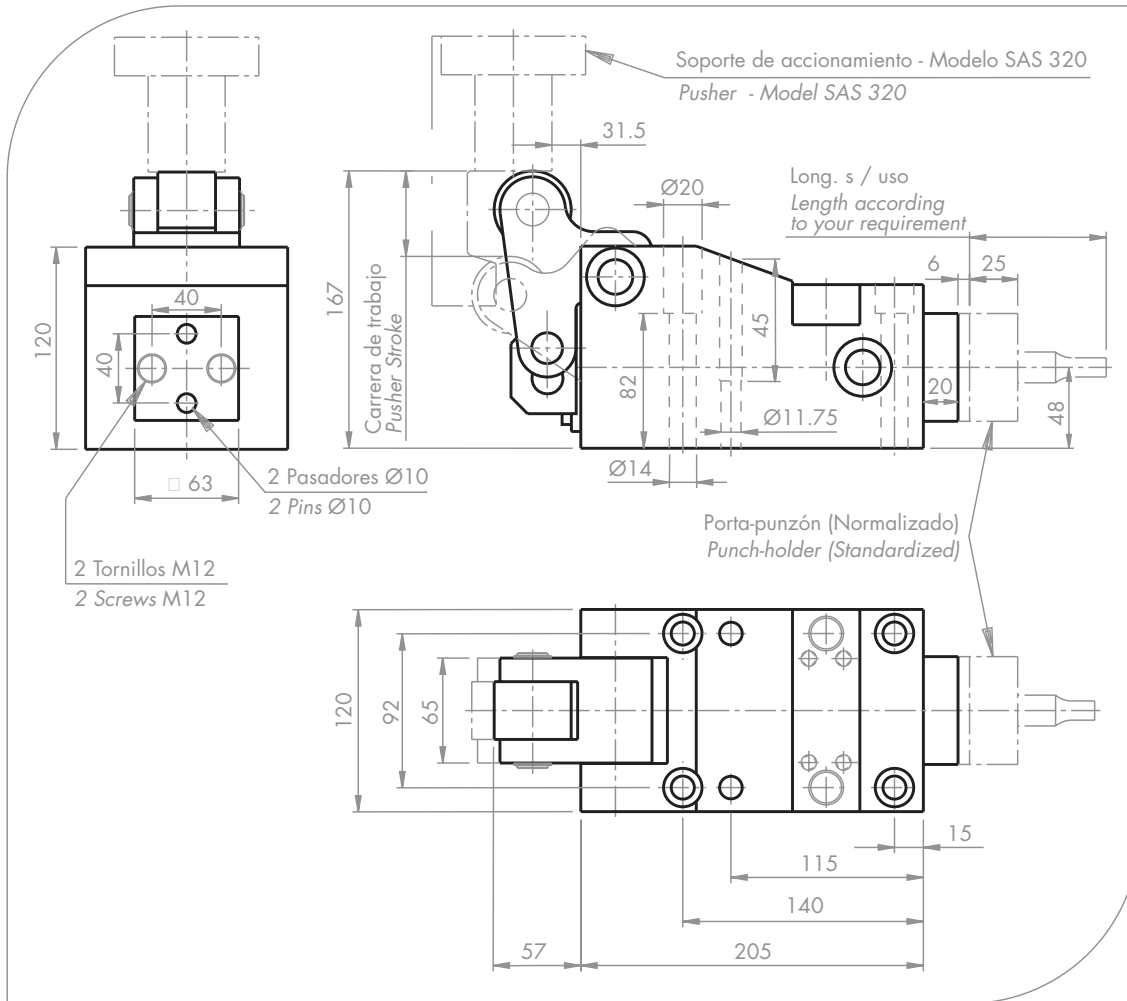

Carrera máx. (mm.) Stroke max.	Fuerza de retroceso (daN) Backward force	Diámetro máx. de punzón (mm.) Max. punch diameter	Fuerza máx. de corte (daN) Cutting max. force
50	500 NCX 750 NCT	25	10000

### EJEMPLO DE PEDIDO / ORDER EXAMPLE

NCX - S - 320

Modelo  
Model

Tipo  
Type

Se recomienda una reserva del 10% de la carrera.  
Azol-Gas se reserva el derecho a efectuar cambios de diseño.

A 10% stroke length allowance is recommended.  
Azol-Gas keeps its right to make any desing modification.

# CUÑA NCX - R45 - 089

## NCX - R45 - 089 CAM UNIT

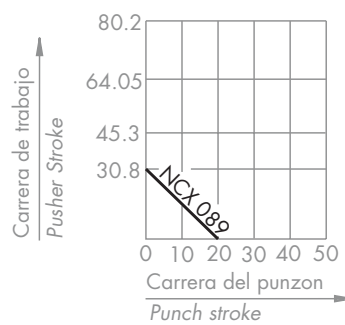
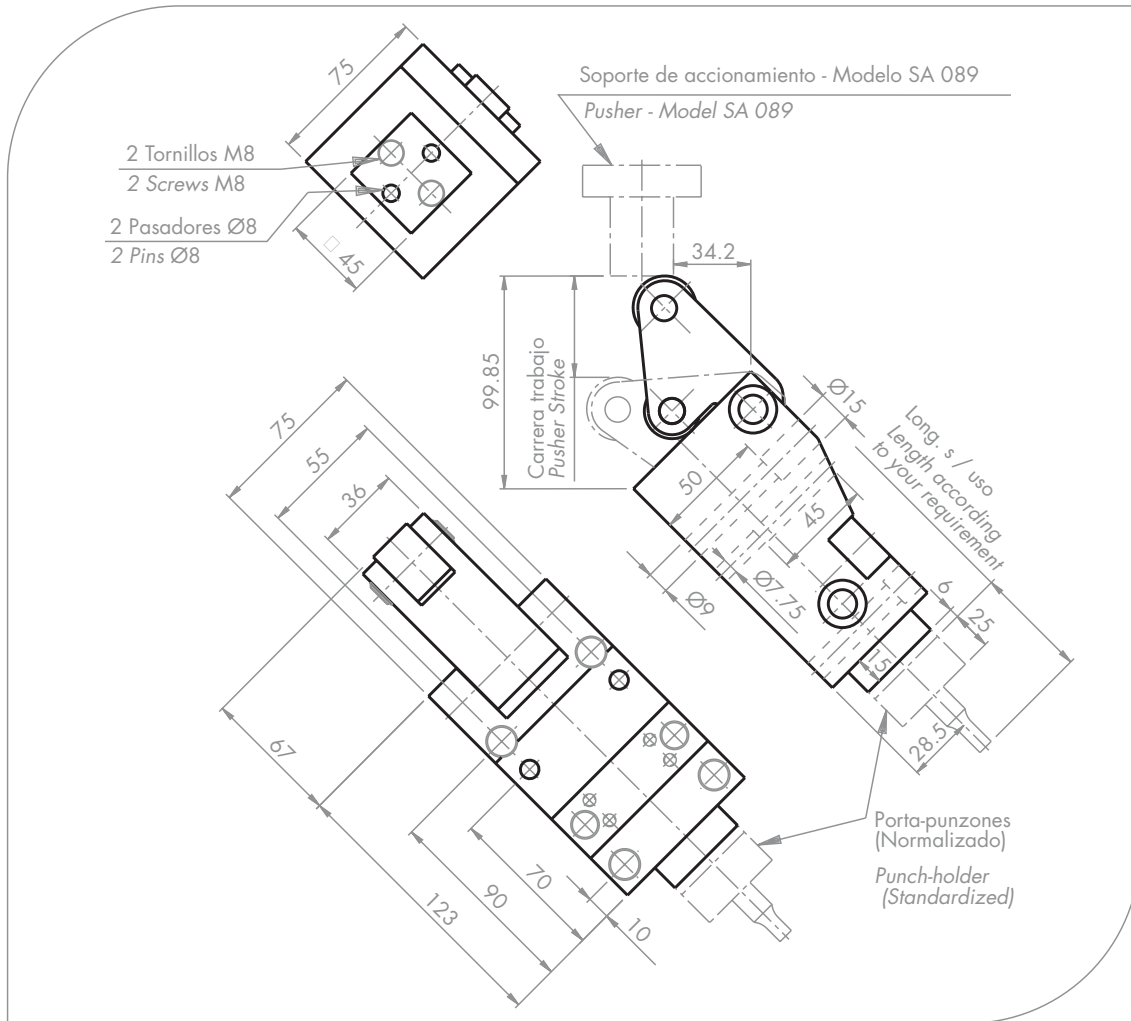

Carrera máx. (mm.) Stroke max.	Fuerza de retroceso (daN) Backward force	Diámetro máx. de punzón (mm.) Max. punch diameter	Fuerza máx. de corte (daN) Cutting max. force
20	150	10	3000

**EJEMPLO DE PEDIDO / ORDER EXAMPLE**

**NCX - R45 - 089**

Modelo  
Model

Tipo  
Type

Se recomienda una reserva del 10% de la carrera.  
Azol-Gas se reserva el derecho a efectuar cambios de diseño.

A 10% stroke length allowance is recommended.  
Azol-Gas keeps its right to make any design modification.

# CUÑA NCX - R45 - 159 NCX - R45 - 159 CAM UNIT

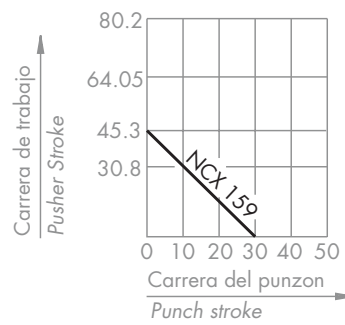
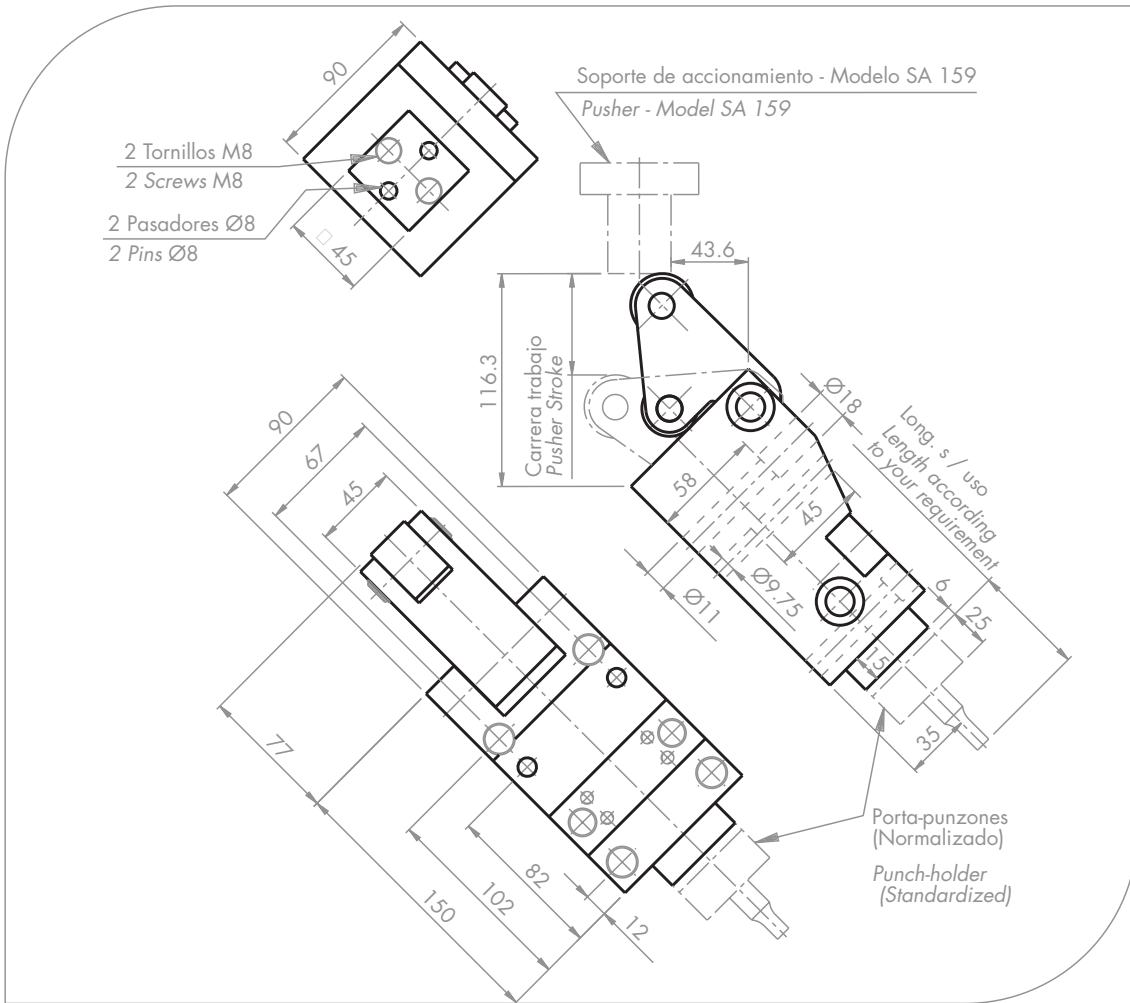

Carrera máx. (mm.) Stroke max.	Fuerza de retroceso (daN) Backward force	Diámetro máx. de punzón (mm.) Max. punch diameter	Fuerza máx. de corte (daN) Cutting max. force
30	200	16	5000

### EJEMPLO DE PEDIDO / ORDER EXAMPLE

NCX - R45 - 159

Modelo  
Model

Tipo  
Type

Se recomienda una reserva del 10% de la carrera.  
Azol-Gas se reserva el derecho a efectuar cambios de diseño.

A 10% stroke length allowance is recommended.  
Azol-Gas keeps its right to make any desing modification.

# CUÑA NCX ( NCT ) - R45 - 199

## NCX ( NCT ) - R45 - 199 CAM UNIT

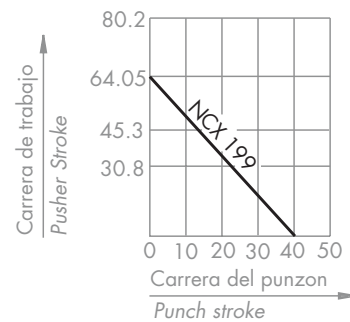
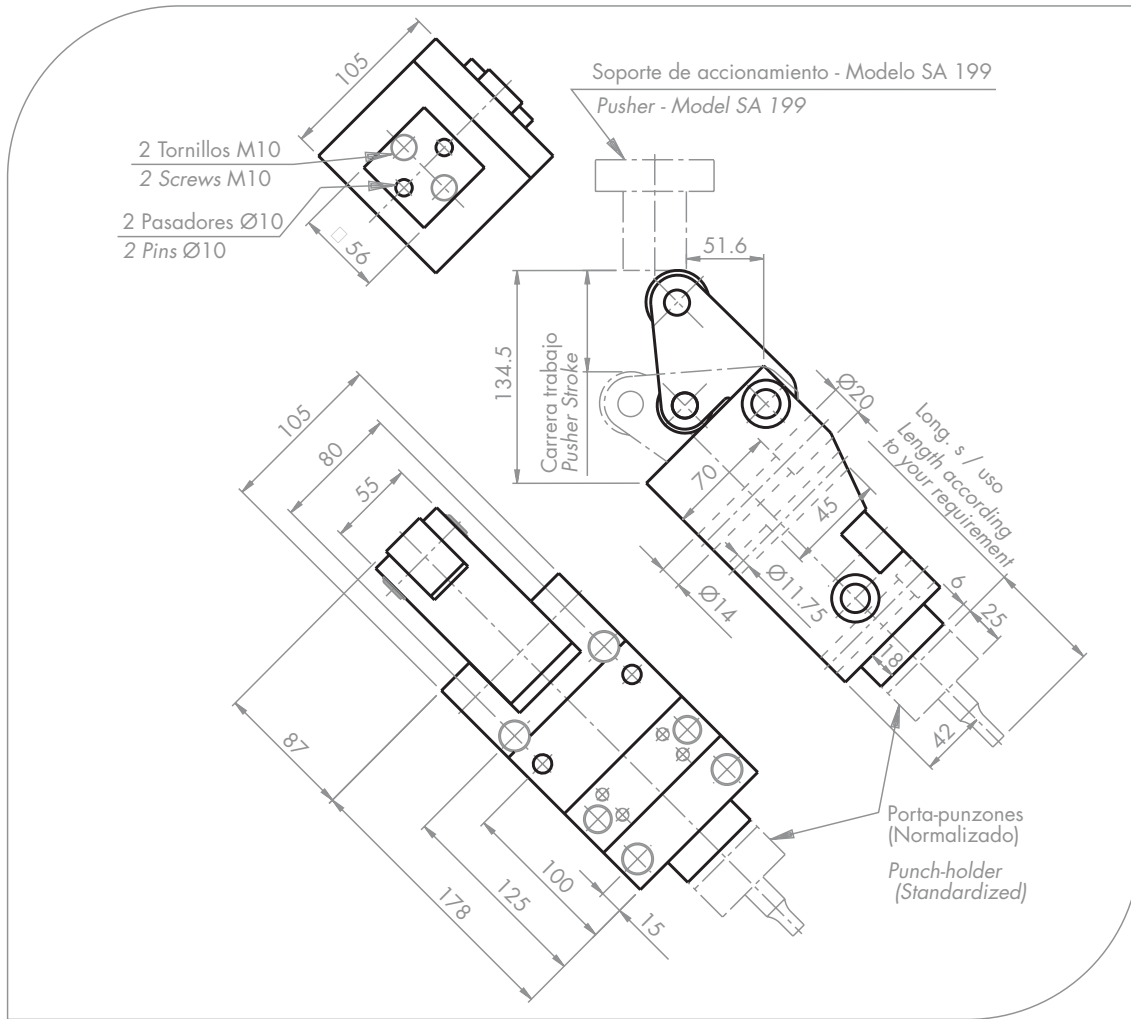

Carrera máx. (mm.) Stroke max.	Fuerza de retroceso (daN) Backward force	Diámetro máx. de punzón (mm.) Max. punch diameter	Fuerza máx. de corte (daN) Cutting max. force
<b>40</b>	250 <sup>NCX</sup> / 500 <sup>NCT</sup>	<b>20</b>	<b>7000</b>

### EJEMPLO DE PEDIDO / ORDER EXAMPLE

**NCX - R45 - 199**

Modelo  
Model

Tipo  
Type

Se recomienda una reserva del 10% de la carrera.  
Azol-Gas se reserva el derecho a efectuar cambios de diseño.

A 10% stroke length allowance is recommended.  
Azol-Gas keeps its right to make any desing modification.

# CUÑA NCX ( NCT ) - R45 - 320

## NCX ( NCT ) - R45 - 320 CAM UNIT

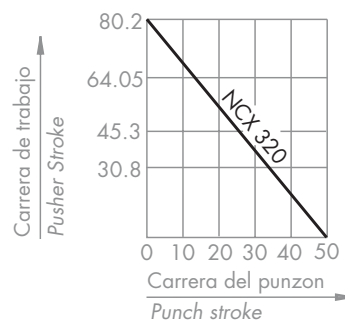
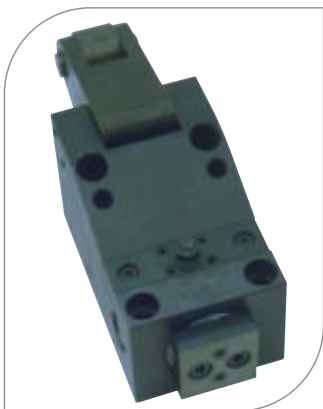
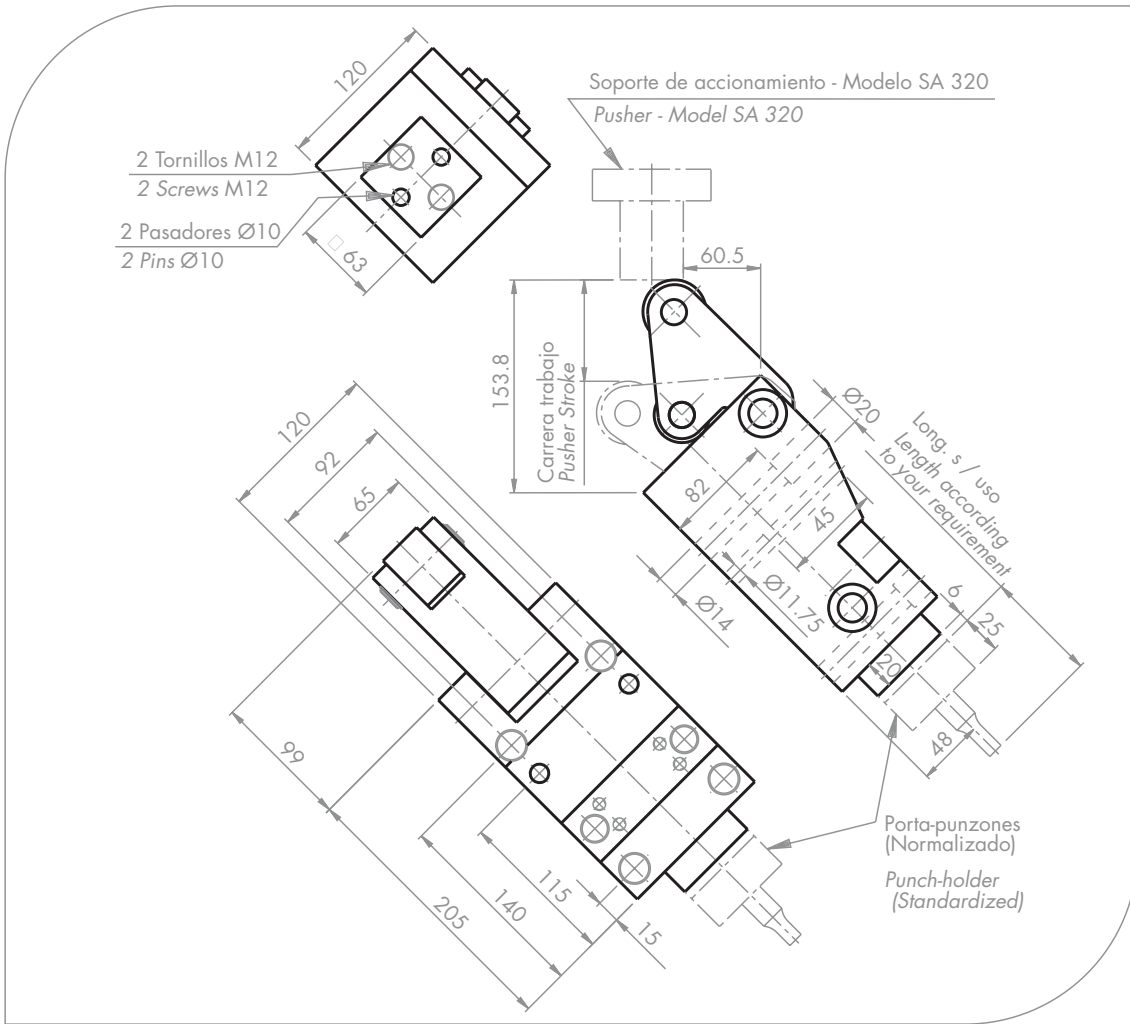

Carrera máx. (mm.) Stroke max.	Fuerza de retroceso (daN) Backward force	Diámetro máx. de punzón (mm.) Max. punch diameter	Fuerza máx. de corte (daN) Cutting max. force
50	500 <sup>NCX</sup> / 750 <sup>NCT</sup>	25	10000

### EJEMPLO DE PEDIDO / ORDER EXAMPLE

NCX - R45 - 320

Modelo  
Model

Tipo  
Type

Se recomienda una reserva del 10% de la carrera.  
Azol-Gas se reserva el derecho a efectuar cambios de diseño.

A 10% stroke length allowance is recommended.  
Azol-Gas keeps its right to make any desing modification.

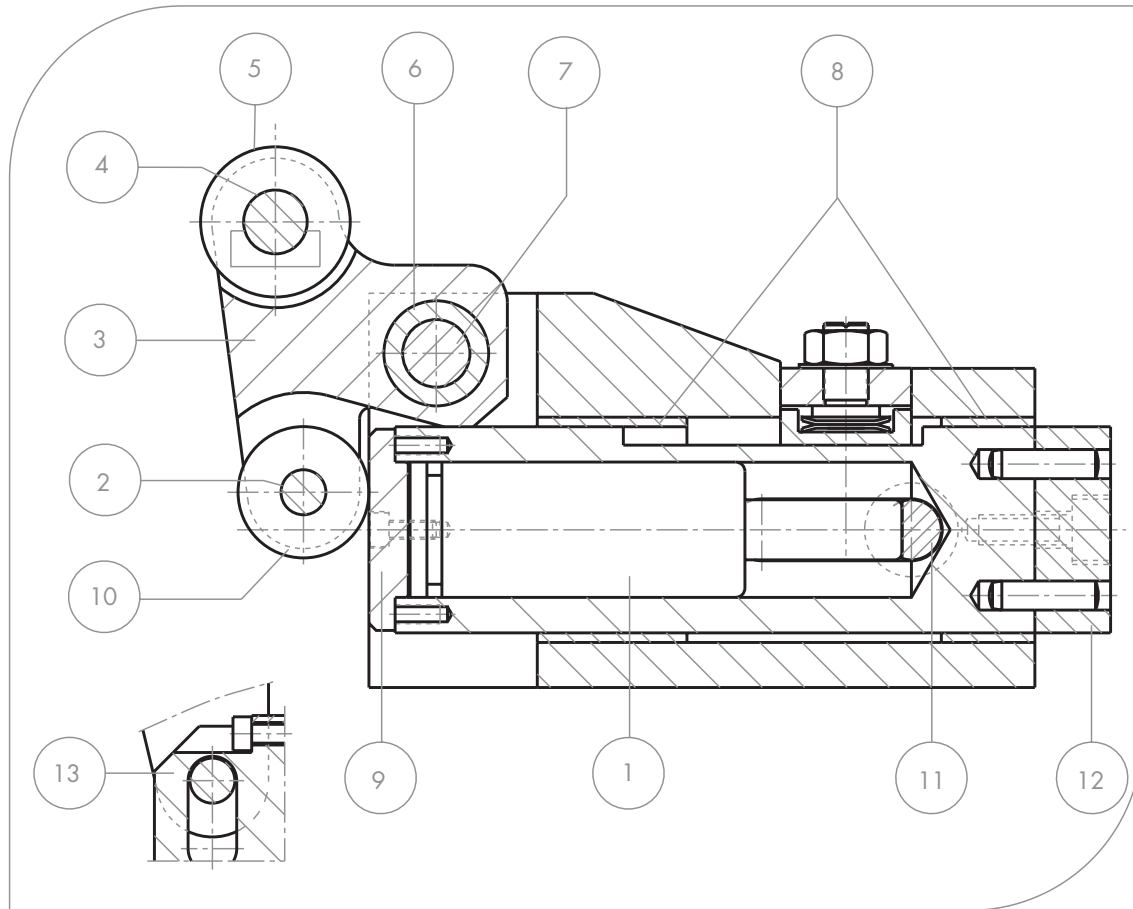

Nº	DENOMINACION DESCRIPTION	MODELO DE CUÑA / WEDGE MODEL			
		NCX 089	NCX 159	NCX 199 NCT 199	NCX 320 NCT 320
1	Cilindro de nitrógeno / Nitrogen gas cylinder	NCX 089.1	NCX 159.1	NCX 199.1 NCT 199.1	NCX 320.1 NCT 320.1
2	Eje rulina / Roller shaft	NCX 089.2	NCX 159.2	NCX 199.2	NCX 320.2
3A	Leva / Cam - Mod. R, S	NCX 089.3	NCX 159.3	NCX 199.3	NCX 320.3
3B	Leva / Cam - Mod. R45	NCX 089.3 R45	NCX 159.3 R45	NCX 199.3 R45	NCX 320.3 R45
4	Eje rulina / Roller shaft	NCX 089.4	NCX 159.4	NCX 199.4	NCX 320.4
5	Rulina / Roller	NCX 089.5	NCX 159.5	NCX 199.5	NCX 320.5
6	Casquillo guía / Bushing	NCX 089.6	NCX 159.6	NCX 199.6	NCX 320.6
7	Eje leva / Cam shaft	NCX 089.7	NCX 159.7	NCX 199.7	NCX 320.7
8	Casquillo DU / DU bushing	NCX 089.8	NCX 159.8	NCX 199.8	NCX 320.8
9	Tapa / Cover	NCX 089.9	NCX 159.9	NCX 199.9 NCT 199.9	NCX 320.9 NCT 320.9
10	Rulina / Roller	NCX 089.10	NCX 159.10	NCX 199.10	NCX 320.10
11	Eje tope / Butt shaft	NCX 089.11	NCX 159.11	NCX 199.11	NCX 320.11
12	Cabezal del eje / Shaft head	NCX 089.12	NCX 159.12	NCX 199.12	NCX 320.12
13	Cabezal de seguridad / Shafty head	NCX 089.13	NCX 159.13	NCX 199.13	NCX 320.13

Se recomienda una reserva del 10% de la carrera.  
Azol-Gas se reserva el derecho a efectuar cambios de diseño.

A 10% stroke length allowance is recommended.  
Azol-Gas keeps its right to make any desing modification.



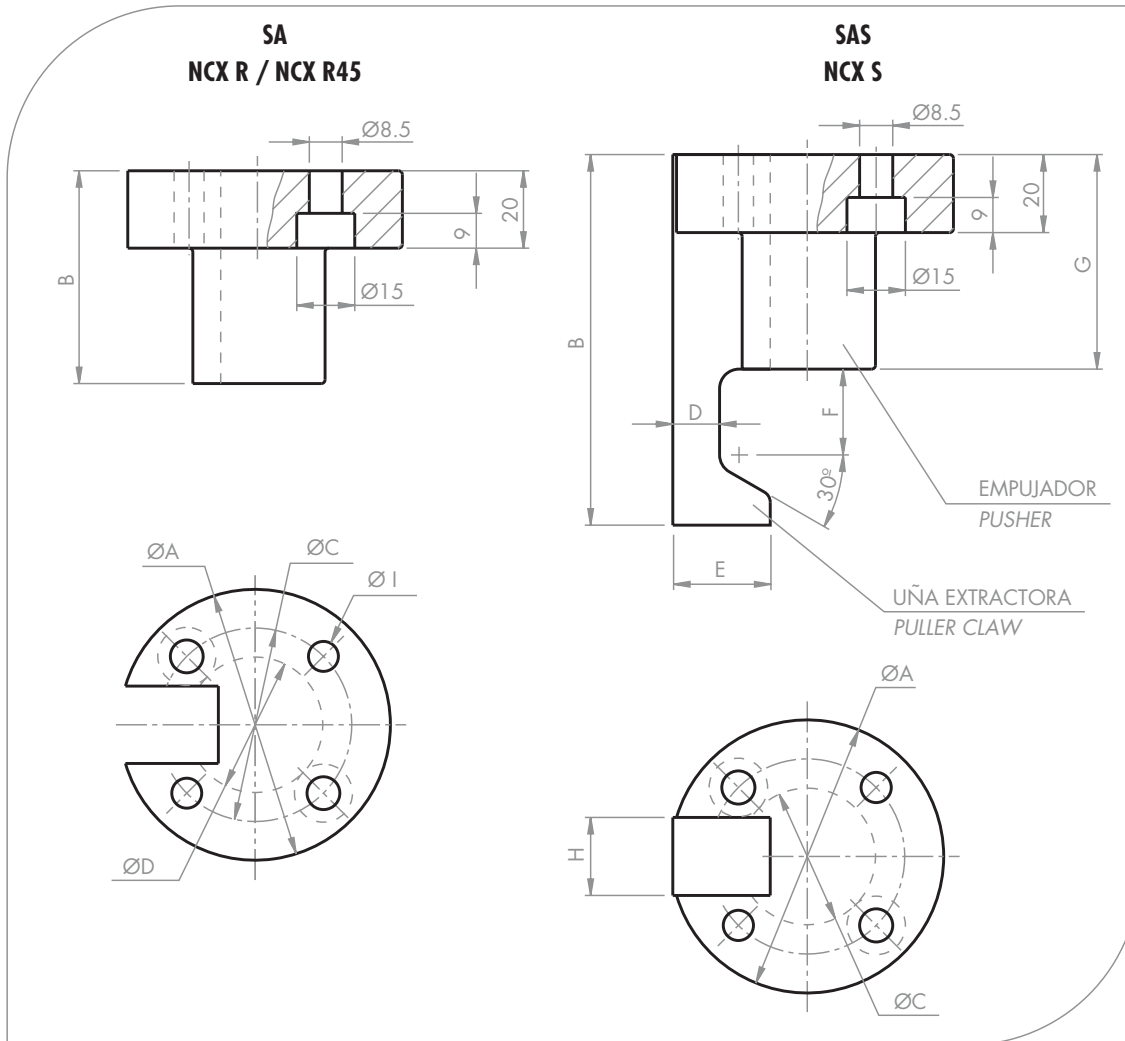

TIPO TYPE	A	B	C	D	E	F	G	H
<b>SAS 089</b>	70	95	35	12	25	22	55	20
<b>SAS 159</b>	70	100	35	12	25	26	55	20
<b>SAS 199</b>	75	125	40	15	30	30	70	22
<b>SAS 320</b>	75	130	40	15	30	35	70	22

TIPO TYPE	A	B	C	D	I
<b>SA 089</b>	70	55	50	35	8
<b>SA 159</b>	70	55	50	35	8
<b>SA 199</b>	75	70	55	40	10
<b>SA 320</b>	75	70	55	40	10

Se recomienda una reserva del 10% de la carrera.  
Azol-Gas se reserva el derecho a efectuar cambios de diseño.

A 10% stroke length allowance is recommended.  
Azol-Gas keeps its right to make any desing modification.

### NOTA

Para liberar el resorte de la cuña, retirar el anillo de sujeción (1) del bulón (2) y empujar hasta extraerlo. Una vez liberado el resorte, el mecanismo de la cuña puede ser accionado manualmente como indica la figura.

### NOTE

To remove the spring from the wedge, extract the retaining ring (1) from the bolt (2) and push till to pull it up. Once the spring is out, wedge mechanism can be operated by hand as the figure shows.

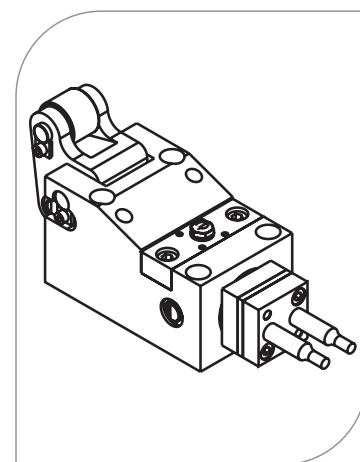
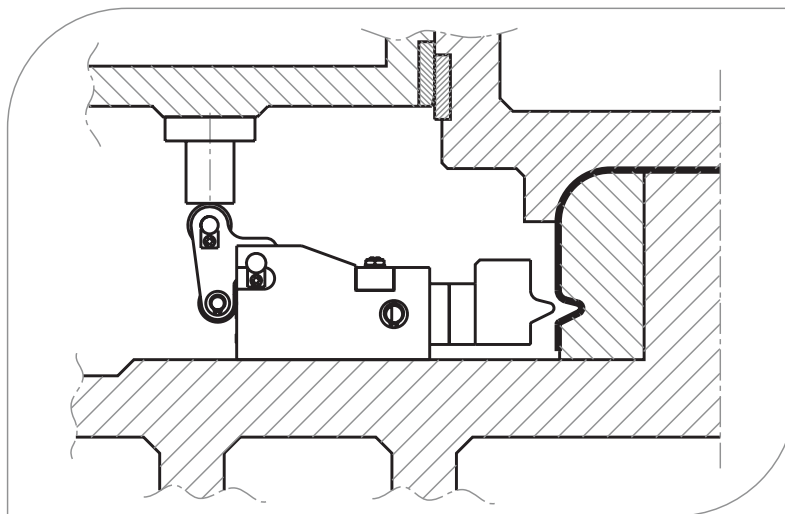
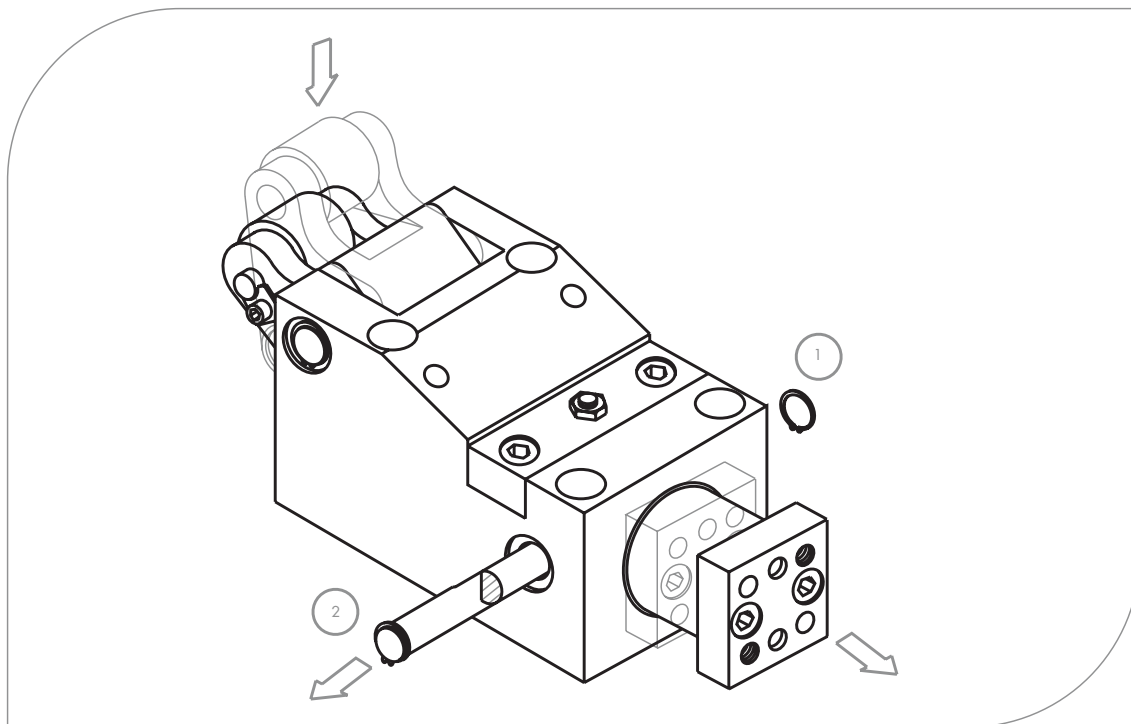

Se recomienda una reserva del 10% de la carrera.  
Azol-Gas se reserva el derecho a efectuar cambios de diseño.

A 10% stroke length allowance is recommended.  
Azol-Gas keeps its right to make any desing modification.

# CUÑAS SX - SXO - LX - LXO SX - SXO - LX - LXO CAM UNITS

PEDIDO BAJO CONSULTA - ORDER UNDER CONSULTATION

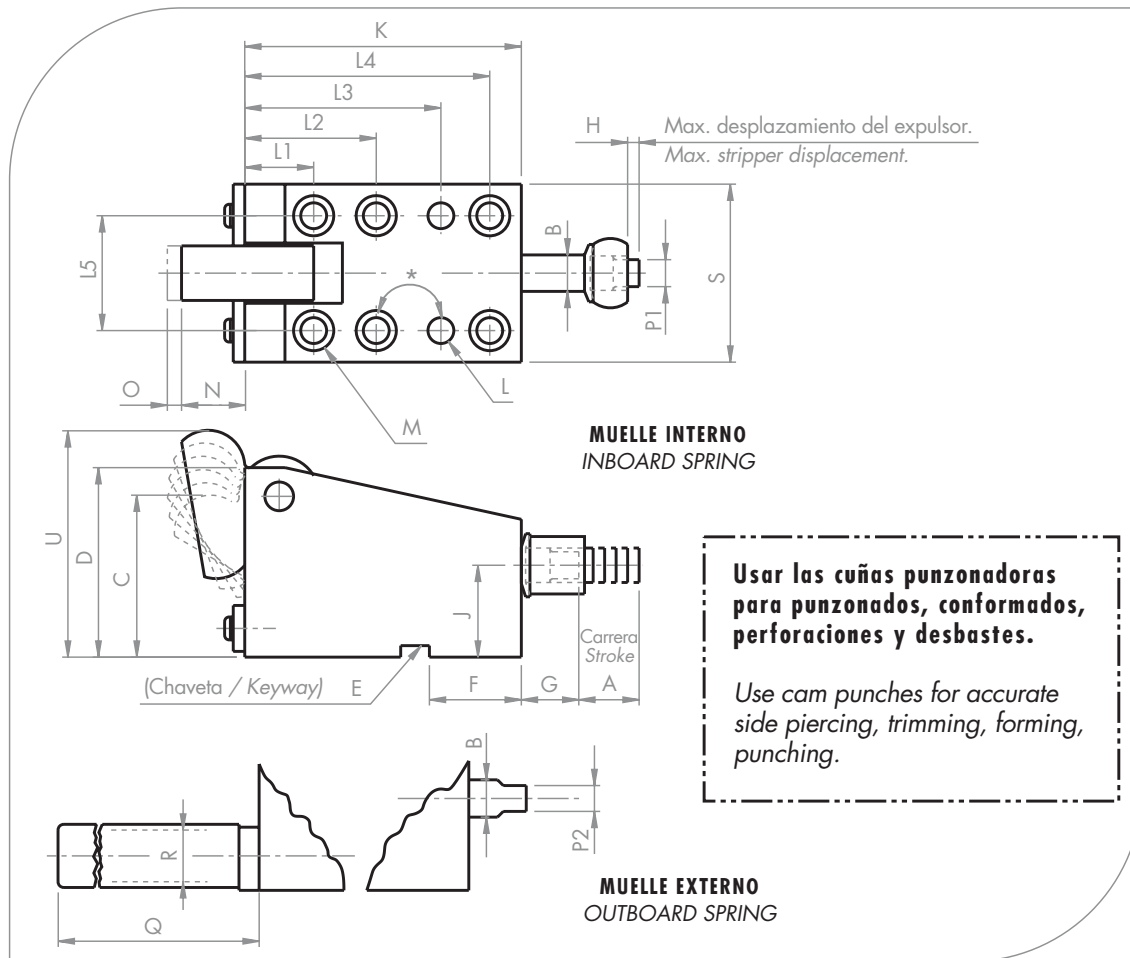

MODELO / MODEL		Max. fuerza de punzonado (daN) Maximum piercing force (daN)	Carrera máx. A (mm.) Stroke max.	Ø Punzones / Point Ø		Ø Eje B (mm.) Shank Ø	Carrera de trabajo C (mm.) Working stroke	U (mm.)
Muelle interno Inboard spring	Muelle externo Outboard spring			Interno Inboard P1	Externo Outboard P2			
SX 250	SXO 250	1500	9.5	1.5 - 4.7	1.5 - 6.4	6.4	42.9	54
SX 375	SXO 375	3000	12.7	3.2 - 8	3.2 - 9.5	9.5	55.6	68
SX 500	SXO 500	5000	16	4.7 - 11	4.7 - 12.7	12.7	57.2	73
SX 625	SXO 625	8000	19	9.5 - 14.3	9.5 - 16	16	63.5	86
LX 250	LXO 250	1500	19	1.5 - 4.7	1.5 - 6.4	6.4	33.3	54
LX 375	LXO 375	3000	22.2	3.2 - 8	3.2 - 9.5	9.5	46	68
LX 500	LXO 500	5000	25.4	4.7 - 11	4.7 - 12.7	12.7	47.6	73
LX 625	LXO 625	8000	28.6	9.5 - 14.3	9.5 - 16	16	55.6	86
SX 75	SXO 75	15000	32	12.7 - 17.5	12.7 - 19	19	79.4	114
SX 87	SXO 87	15000	32	16 - 20.6	16 - 22	22	79.4	114
SX 100	SXO 100	15000	32	19 - 24	19 - 25	25	79.4	114
SX 125	SXO 125	25000	38	22 - 28.6	22 - 32	32	131.8	170
SX 137	SXO 137	25000	38	25 - 31	25 - 35	35	131.8	170
SX 150	SXO 150	25000	38	28.6 - 35	28.6 - 38	38	131.8	170
LX 75	LXO 75	15000	51	12.7 - 17.5	12.7 - 19	19	65.1	114
LX 87	LXO 87	15000	51	16 - 20.6	16 - 22	22	65.1	114
LX 100	LXO 100	15000	51	19 - 24	19 - 25	25	65.1	114
LX 125	LXO 125	25000	63.5	22 - 28.6	22 - 32	32	109.5	170
LX 137	LXO 137	25000	63.5	25 - 32	25 - 35	35	109.5	170
LX 150	LXO 150	25000	63.5	28.6 - 35	28.6 - 38	38	109.5	170

Se recomienda una reserva del 10% de la carrera.  
Azol-Gas se reserva el derecho a efectuar cambios de diseño.

A 10% stroke length allowance is recommended.  
Azol-Gas keeps its right to make any desing modification.

# CUÑAS SX - SXO - LX - LXO SX - SXO - LX - LXO CAM UNITS

PEDIDO BAJO CONSULTA - ORDER UNDER CONSULTATION

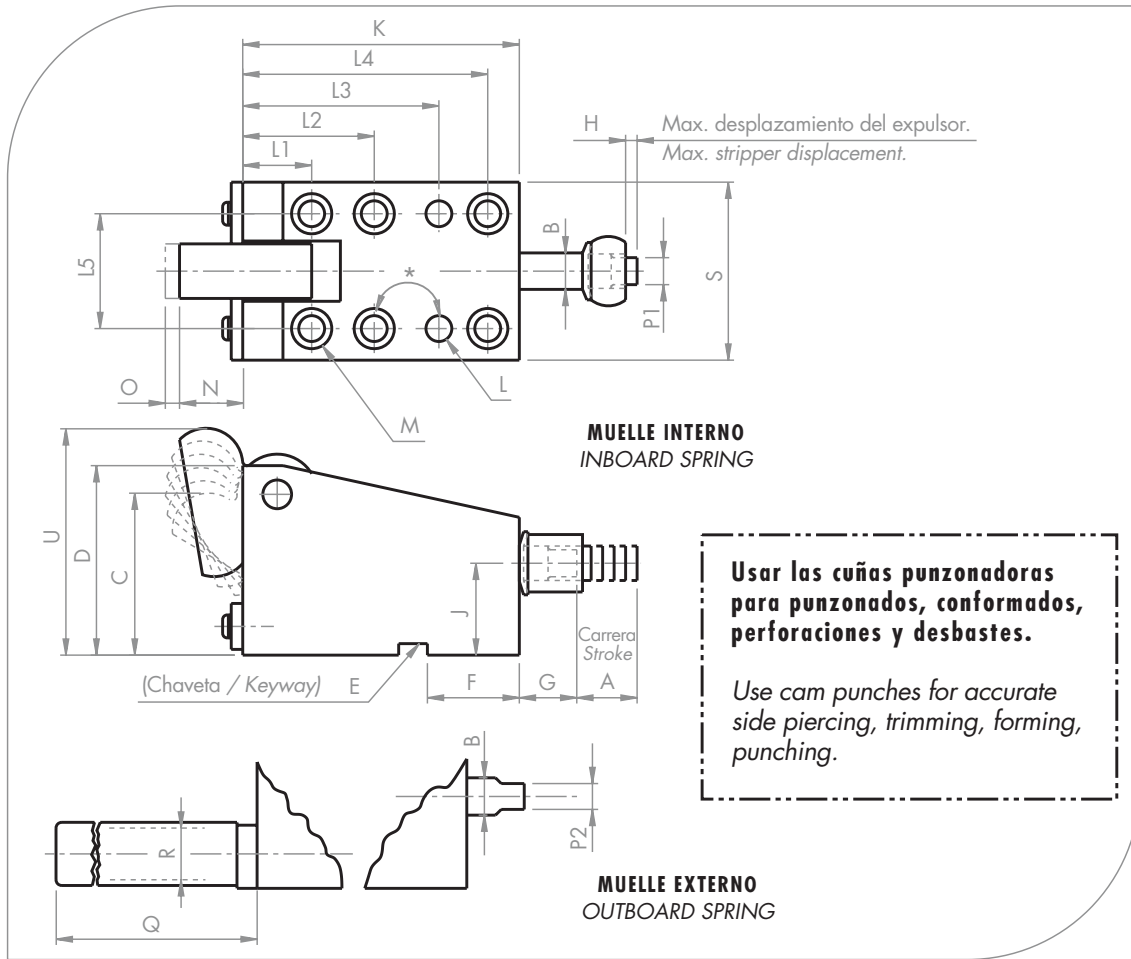

MODELO / MODEL		L1 (mm.)	L2 (mm.)	L3 (mm.)	L4 (mm.)	L5 (mm.)
Muelle interno Inboard spring	Muelle externo Outboard spring					
SX 250 *	SXO 250 *	-	23 / 37	23 / 37	-	30
SX 375 *	SXO 375 *	-	26 / 46	26 / 46	-	36
SX 500 *	SXO 500 *	-	29 / 55	29 / 55	-	46
SX 625 *	SXO 625 *	-	33 / 63	33 / 63	-	50
LX 250	LXO 250	-	23	50	62	30
LX 375	LXO 375	-	27	60	73	36
LX 500	LXO 500	-	40	65	80	46
LX 625	LXO 625	-	35	66	90	50
SX 75	SXO 75	-	40	80	100	64
SX 87	SXO 87	-	40	80	100	64
SX 100	SXO 100	-	40	80	100	64
SX 125	SXO 125	-	55	110	135	70
SX 137	SXO 137	-	55	110	135	70
SX 150	SXO 150	-	55	110	135	70
LX 75	LXO 75	50	90	130	150	64
LX 87	LXO 87	50	90	130	150	64
LX 100	LXO 100	50	90	130	150	64
LX 125	LXO 125	55	125	170	200	70
LX 137	LXO 137	55	125	170	200	70
LX 150	LXO 150	55	125	170	200	70

Se recomienda una reserva del 10% de la carrera.  
Azol-Gas se reserva el derecho a efectuar cambios de diseño.

A 10% stroke length allowance is recommended.  
Azol-Gas keeps its right to make any desing modification.

**PEDIDO BAJO CONSULTA - ORDER UNDER CONSULTATION**

MODELO / MODEL		D	Chaveta E Keyway	F	G	H (Max.)	J	K	L	M	N	O	Q	R	S
Muelle interno Inboard spring	Muelle externo Outboard spring														
SX 250	SXO 250	45	4.8 x 2.4	13	22	6.4	21	45	2 - Ø6	2 - Ø6	12.7	4.8	73	16	45
SX 375	SXO 375	57	6.4 x 3.2	18	22	6.4	29	57	2 - Ø8	2 - Ø8	15.9	6.35	98	20	57
SX 500	SXO 500	64	8 x 4	21	22	6.4	30	64	2 - Ø8	2 - Ø8	15.9	6.35	111	20	64
SX 625	SXO 625	76	9.5 x 4.8	25	22	6.4	38	76	2 - Ø10	2 - Ø10	23.8	4.8	124	25	76
LX 250	LXO 250	45	4.8 x 2.4	25	22	6.4	21	70	2 - Ø6	4 - Ø6	12.7	4.8	105	16	45
LX 375	LXO 375	57	6.4 x 3.2	30	22	6.4	29	83	2 - Ø8	4 - Ø8	15.9	6.35	137	20	57
LX 500	LXO 500	64	8 x 4	32	22	6.4	30	89	2 - Ø8	4 - Ø8	15.9	6.35	149	20	64
LX 625	LXO 625	76	9.5 x 4.8	48	22	6.4	38	102	2 - Ø10	4 - Ø10	23.8	4.8	162	25	76
SX 75	SXO 75	95	12.7 x 6.4	48	29	9.5	46	114	2 - Ø12	4 - Ø12	30.9	7.9	162	32	89
SX 87	SXO 87														
SX 100	SXO 100														
SX 125	SXO 125														
SX 137	SXO 137	140	12.7 x 6.4	54	41	9.5	67	152	2 - Ø12	4 - Ø12	49.2	9.5	191	40	102
SX 150	SXO 150	95	12.7 x 6.4	48	29	9.5	46	165	2 - Ø12	6 - Ø12	30.9	7.9	238	32	89
LX 75	LXO 75														
LX 87	LXO 87														
LX 100	LXO 100														
LX 125	LXO 125	140	12.7 x 6.4	64	41	9.5	67	216	2 - Ø12	6 - Ø12	49.2	9.5	292	40	102
LX 137	LXO 137														
LX 150	LXO 150														

**COMO PEDIR**

Especificar cantidad, nº de modelo y la cota "P" ó "P y W".

**HOW TO ORDER**

Specify quantity, model number, and "P" or "P & W" dimension.

**Redondo standard**  
Standard round



**Oblongado**  
Oblong

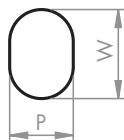

**Cuadrado**  
Square



**Rectangular**  
Rectangular

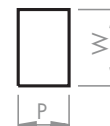
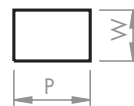

"P" es horizontal a la base de la cuña.  
"P" is horizontal to base line of cam unit.

**CARACTERISTICAS**

- \* Construido con piezas de acero endurecido para una mayor vida.
- \* Un sólo gatillo actuador supone una actuación positiva.
- \* Compacta, pequeña.
- \* Pueden montarse con ángulos.
- \* Diseños especiales disponibles.

**FEATURES**

- \* Built with hardened steel parts for long life.
- \* Unique pivot trigger provides positive actuation.
- \* Compact, low profile saves space.
- \* May be angle mounted.
- \* Special designs available.

Se recomienda una reserva del 10% de la carrera.  
Azol-Gas se reserva el derecho a efectuar cambios de diseño.

A 10% stroke length allowance is recommended.  
Azol-Gas keeps its right to make any desing modification.

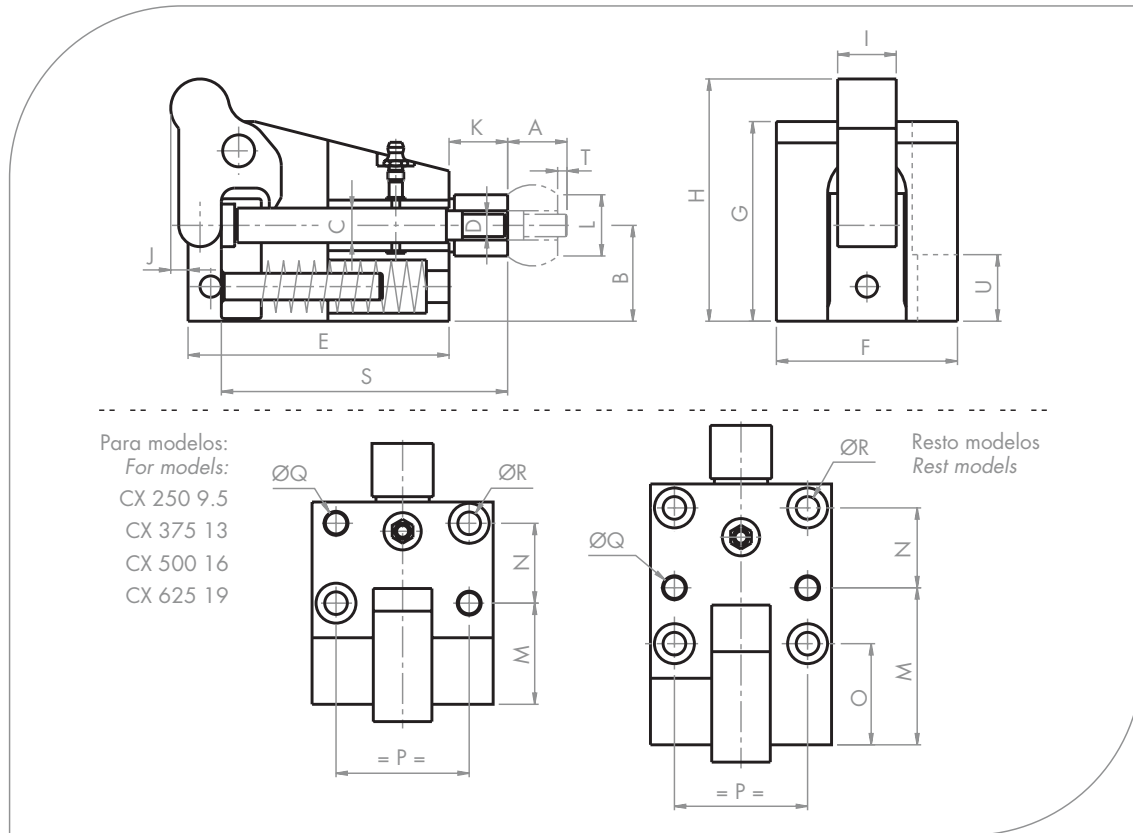

### PARAMETROS OPERATIVOS

El punzonado se debe realizar en el último cuarto de carrera.  
El espacio de corte debe ser, al menos, un 10% del espesor de la placa.  
Máximo ángulo estándar de montaje 15°.  
Las fuerzas de reacción son absorbidas por la chaveta, montada en la parte posterior de la unidad.  
La carrera del punzón es igual a la carrera de la prensa.

### OPERATING PARAMETERS

Piercing should take place during the last quarter of the max. stroke A.  
Cutting clearance per side 10% min. of stock thickness.  
Standard angle mounting of 15° max.  
Reaction forces absorbed through a key, mounted at the rear of the unit.  
Punch stroke equal to press stroke.

MODELO MODEL	Carrera Stroke	Fuerza (max) Ton	B	C	D	E	F	G	H	I	J	K	L	M	N	O	P	Q	R	S	T	U
CX 250	9.5	1	22	6	1.5 - 4.7	51	51	47	59	15	6	22	18	26	18	-	37	6	M6	63	6	15
	76					50								26		88						
CX 375	13	2	32	10	3.2 - 7.9	64	64	63	75	19	5	22	21	32	23	-	46	8	M8	75	6	20
	91					57								32		102						
CX 500	16	3	36	13	4.7 - 11	75	68	75	91	22	6.5	22	23	38	30	-	50	8	M8	84.5	6	25
	98					59								38		107.5						
CX 625	19	5	42	16	9.5 - 14.2	87	78	87	106	24	9	22	28	42	35	-	56	10	M10	94	6	25
	112					66								42		119						
CX 1000	32	10	48	25	19 - 22.4	126	92	106	129	28	15	28.5	45	77	35	50	66	16	M14	139.5	9	30
	258					110								50		171.5						
CX 1500	38	18	67	38	28.6 - 31	168	105	146	180	41	24	41.5	63	105	45	62	79	16	M14	190.5	9	40
	231					168								62		253.5						

Se recomienda una reserva del 10% de la carrera.  
Azol-Gas se reserva el derecho a efectuar cambios de diseño.

A 10% stroke length allowance is recommended.  
Azol-Gas keeps its right to make any desing modification.

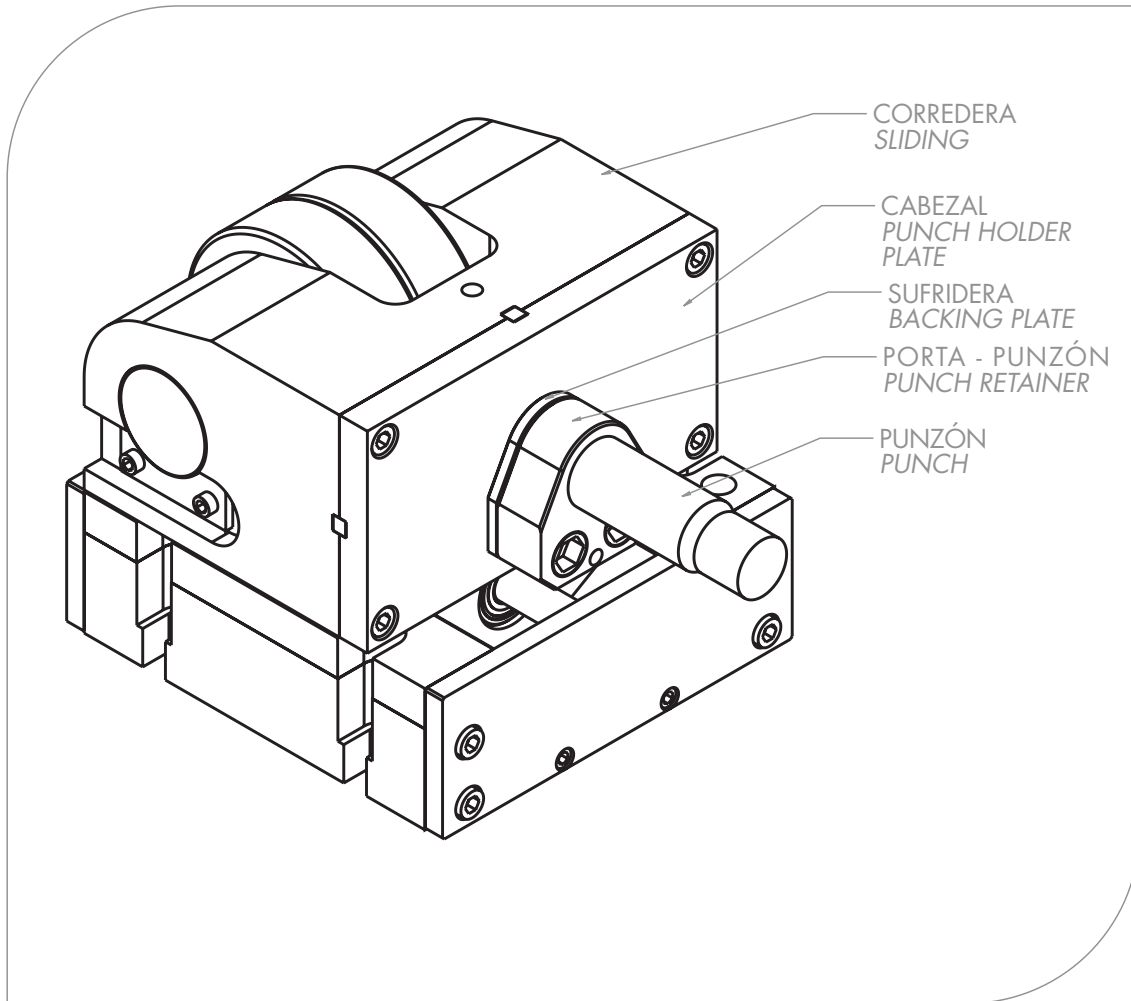

**\* Se recomienda que el esfuerzo de corte (punzón), vaya lo más centrado posible sobre el cabezal del carro, para evitar en lo posible desgastes irregulares de los elementos de guiado, y alargar así su vida útil.**

*\* It is advisable the punch to be located as centered as possible on the punch holder plate of the cam in order to avoid irregular wearing on the guiding elements and so enlarge the live expectancy for the unit.*

**Se recomienda una reserva del 10% de la carrera. Azol-Gas se reserva el derecho a efectuar cambios de diseño.**

*A 10% stroke length allowance is recommended. Azol-Gas keeps its right to make any desing modification.*

# CARRO ECX.03 ECX.03 ROLLER CAM

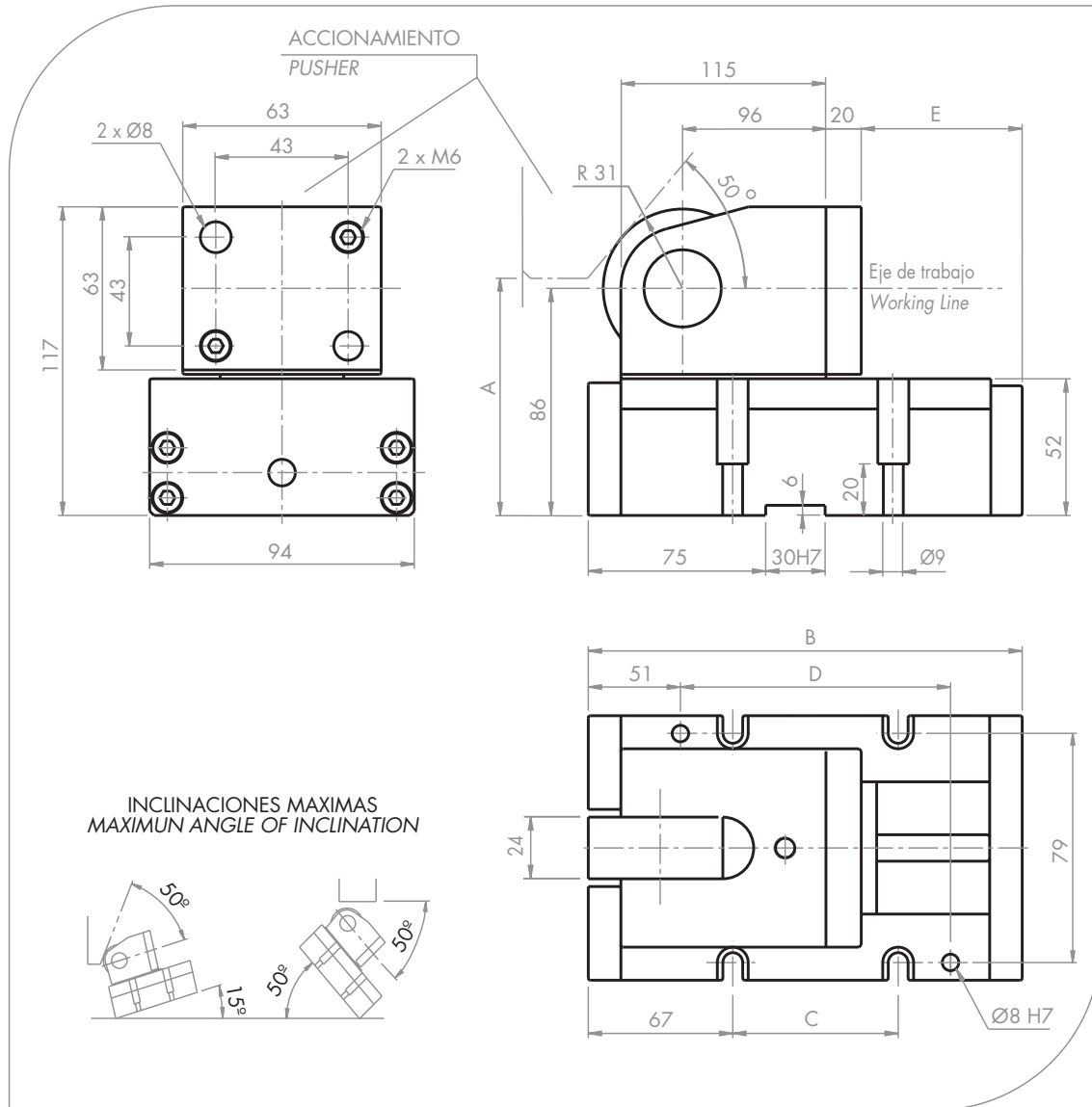

MODELO DE CARRO CAM MODEL	Carrera Stroke	A	B	C	D	E
<b>ECX.03.50</b>	50	60	190	56	88	43
<b>ECX.03.80</b>	80	96	220	86	118	73

MODELO DE CARRO CAM MODEL	Carrera máx. recomendada Recommended max. stroke	Máxima fuerza de punzonado (daN) Maximum piercing force	Fuerza de retroceso (daN) Backward force
<b>ECX.03.50</b>	45	3000	200
<b>ECX.03.80</b>	72		

### EJEMPLO DE PEDIDO / ORDER EXAMPLE

ECX 03 - 50

Modelo  
Model + Fuerza Tm.  
Force Tm.

Tipo  
Type

Se recomienda una reserva del 10% de la carrera.  
Azol-Gas se reserva el derecho a efectuar cambios de diseño.

A 10% stroke length allowance is recommended.  
Azol-Gas keeps its right to make any desing modification.



# CARRO ECX.05 ECX.05 ROLLER CAM

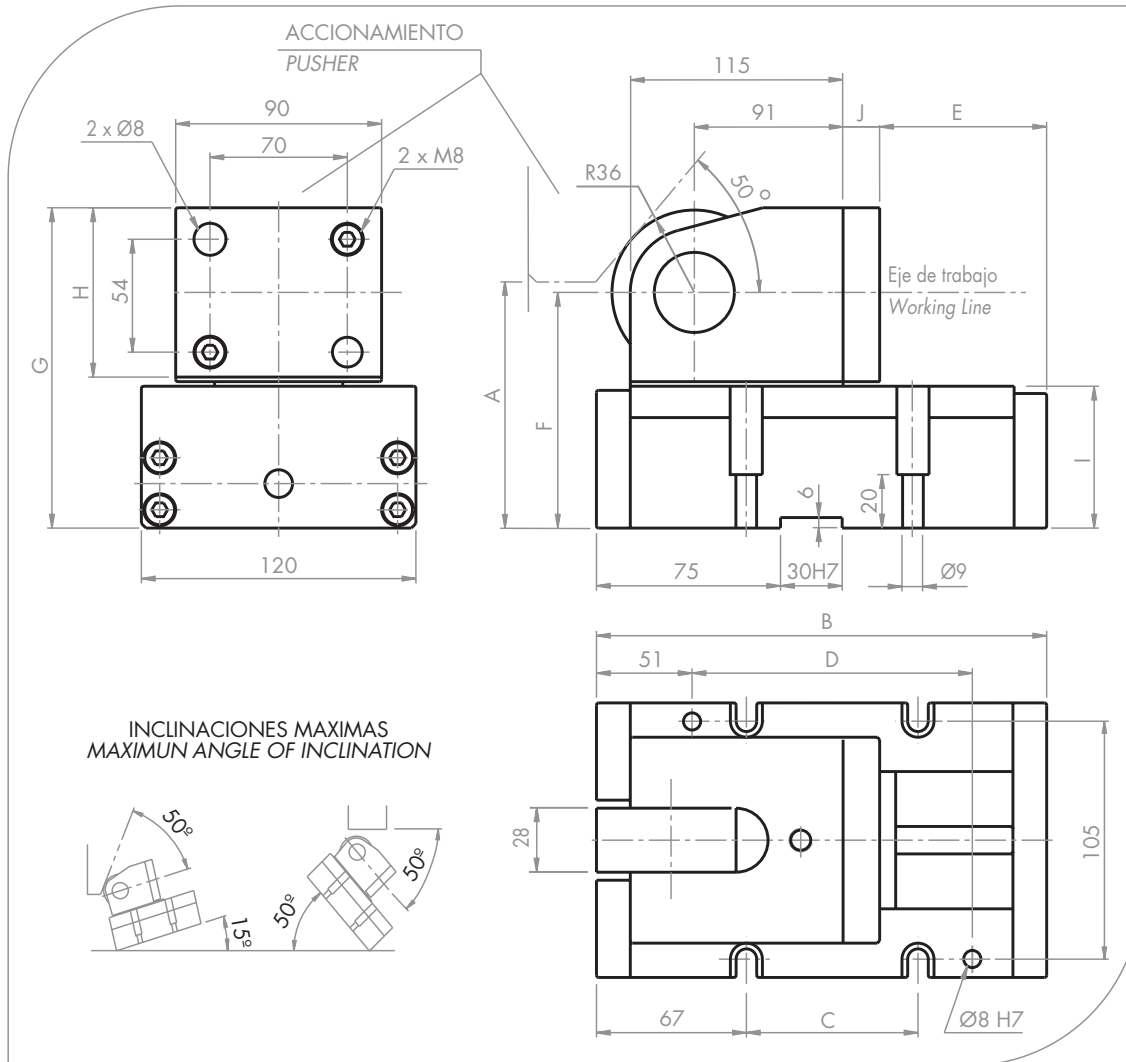

MODELO DE CARRO CAM MODEL	Carrera Stroke	A	B	C	D	E	F	G	H	I	J
ECX.05.50	50	60	190	56	88	43	103	140	74	62	20
ECX.05.80	80	96	220	86	118	73	103	140	74	62	20
ECX.05.100	100	120	260	126	158	103	120	157	74	79	30

MODELO DE CARRO CAM MODEL	Carrera máx. recomendada Recommended max. stroke	Máxima fuerza de punzonado (daN) Maximum piercing force	Fuerza de retroceso (daN) Backward force
ECX.05.50	45	5000	200
ECX.05.80	72		
ECX.05.100	90		

### EJEMPLO DE PEDIDO / ORDER EXAMPLE

ECX 05 - 80

Modelo + Fuerza Tm.  
Model + Force Tm.

Tipo  
Type

Se recomienda una reserva del 10% de la carrera.  
Azol-Gas se reserva el derecho a efectuar cambios de diseño.

A 10% stroke length allowance is recommended.  
Azol-Gas keeps its right to make any desing modification.

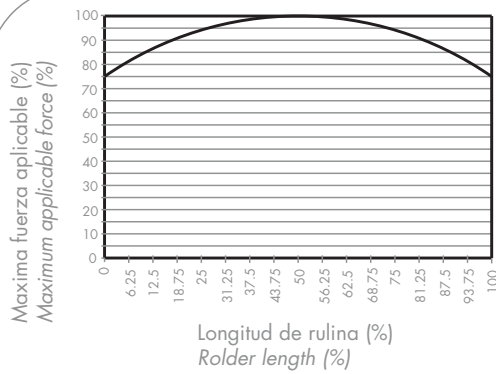
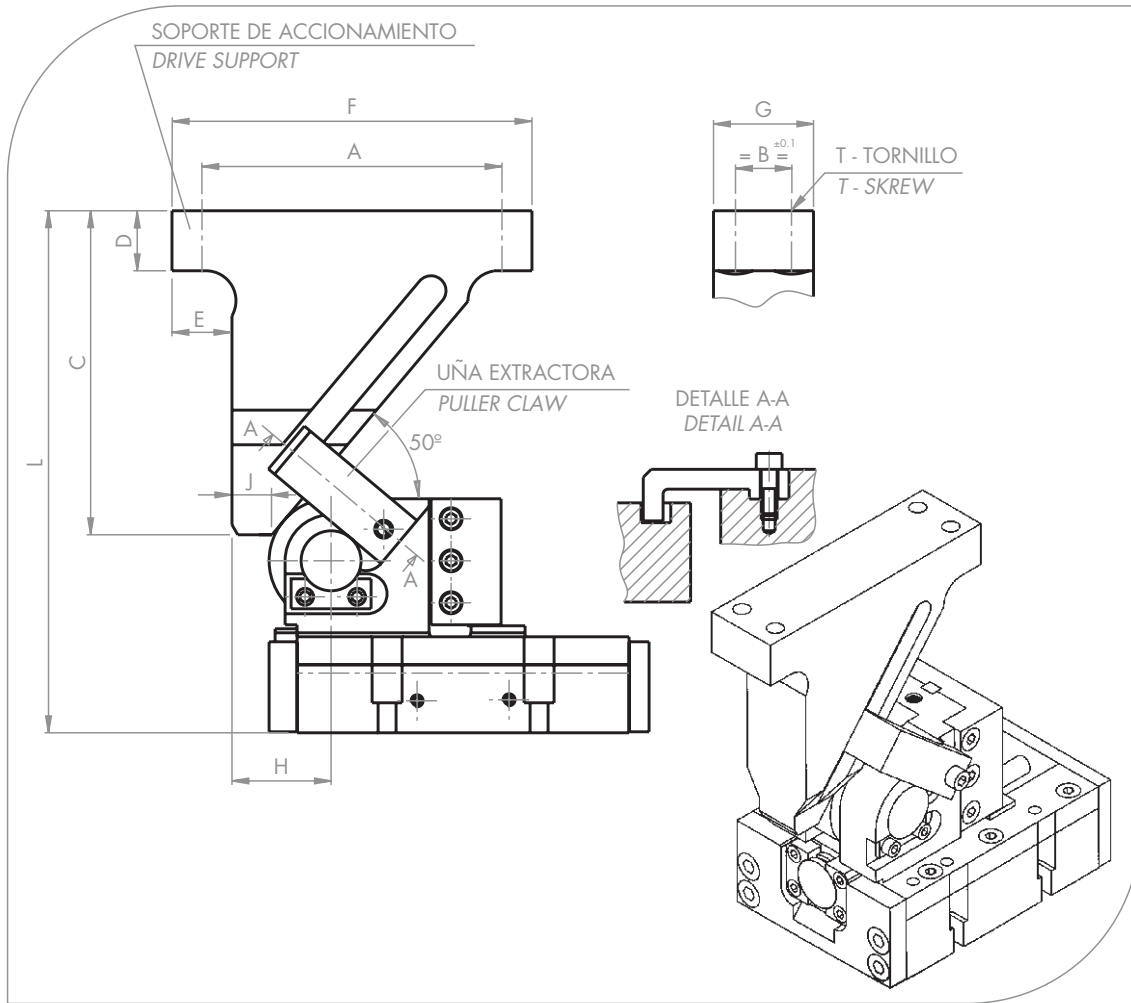

**Máxima fuerza aplicable sobre la rulina, cuando el soporte de accionamiento no actúa sobre el centro de dicha rulina.**

*Maximum applicable force on the roller when the driver does not work centered on the roller.*

TIPO TYPE	A	B	C	D	E	F	G	L	J	T	H
OCX.03.50	150	28	162	30	30	180	50	261	20	M10	49.6
OCX.03.80	180	28	199	30	30	210	50	298	20	M10	49.6
OCX.03.100	200	28	220	30	30	230	50	343	20	M10	49.6
OCX.05.50	150	28	162	30	30	180	50	278	20	M10	57.4
OCX.05.80	180	28	199	30	30	210	50	315	20	M10	57.4
OCX.05.100	200	28	220	30	30	230	50	353	20	M10	57.4
OCX.15.50	192	30	190	40	40	222	60	323	25	M12	72.8
OCX.15.80	222	30	226	40	40	252	60	359	25	M12	72.8
OCX.15.100	244	30	250	40	40	274	60	383	25	M12	72.8
OCX.20.50	192	30	190	40	40	222	60	340	25	M12	84.2
OCX.20.80	222	30	226	40	40	252	60	376	25	M12	84.2
OCX.20.100	244	30	250	40	40	274	60	400	25	M12	84.2

### EJEMPLO DE PEDIDO / ORDER EXAMPLE

OCX - 03 - 50 - SOPORTE DE ACCIONAMIENTO / UÑA EXTRACTORA  
DRIVE SUPPORT / PULLER CLAW

Modelo / Model      Fuerza daN / Force daN      Carrera mm. / Stroke mm.      Opcional / Optional

Se recomienda una reserva del 10% de la carrera.

Azol-Gas se reserva el derecho a efectuar cambios de diseño.

A 10% stroke length allowance is recommended.  
Azol-Gas keeps its right to make any design modification.

# CARRO OCX.02 OCX.02 ROLLER CAM

## OCX

**CARRO CON CABEZAL PLANO DE AMARRE FRONTAL.**

**CAM WITH FRONT FASTENING FLAT HEAD.**

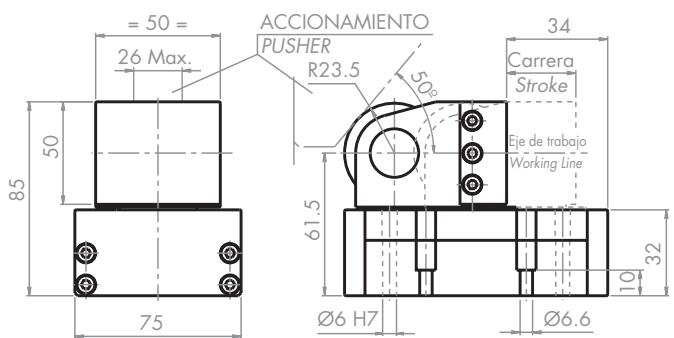
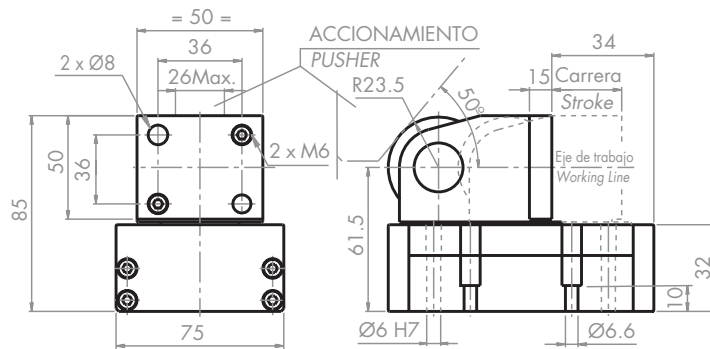

## OCX-R

**INCLINACIONES MAXIMAS  
MAXIMUM ANGLE OF INCLINATION**

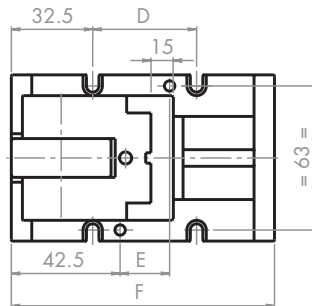
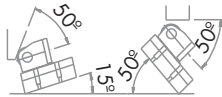

**CARRO CON CABEZAL EN "U"  
PARA AMARRE LATERAL.  
ESTE AMARRE PERMITE  
DESMONTAR EL CABEZAL  
SIN SOLTAR EL PUNZON.**

**CAM WITH "U" SHAPES SIDE  
FASTENING. THIS FASTENING  
ALLOWS HEAD DISSASSEMBLING  
WITH PUNCH MOUNTED.**

MODELO DE CARRO CAM MODEL	Carrera máx. recomendada Recommended max. stroke	D	E	F	Cilindro Spring
OCX.03.22	22	50	30	115	AFJ 90 x 25
OCX.03.35	35	71	51	136	AFJ 90 x 38

MODELO DE CARRO CAM MODEL	Fuerza máxima de punzonado (daN) Maximum puching force (daN)	Fuerza de retroceso (daN) Backward force (daN)	Nº de tornillos del cabezal No. of screws on front
OCX.02.22	2000	90	2
OCX.02.35			

### EJEMPLO DE PEDIDO / ORDER EXAMPLE

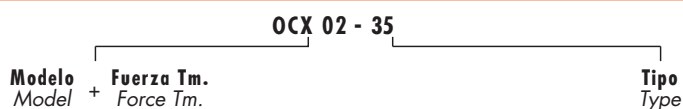

Se recomienda una reserva del 10% de la carrera.  
Azol-Gas se reserva el derecho a efectuar cambios de diseño.

A 10% stroke lenght allowance is recommended.  
Azol-Gas keeps its right to make any desing modification.

## OCX / OCT

### CARRO CON CABEZAL PLANO DE AMARRE FRONTAL.

CAM WITH FRONT FASTENING FLAT HEAD.

Cotas entre ( ), para carros de carrera 100.

Dimensions in ( ), for 100 stroke cam.

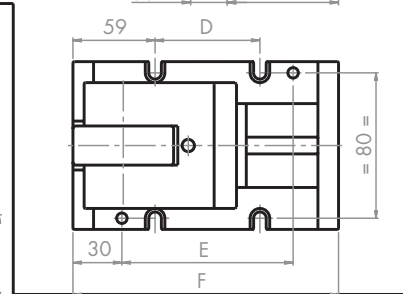
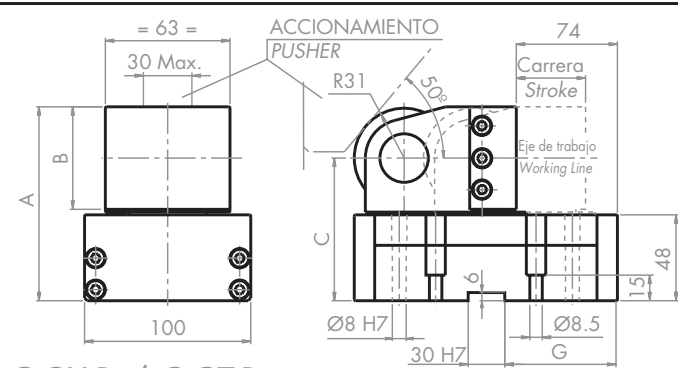
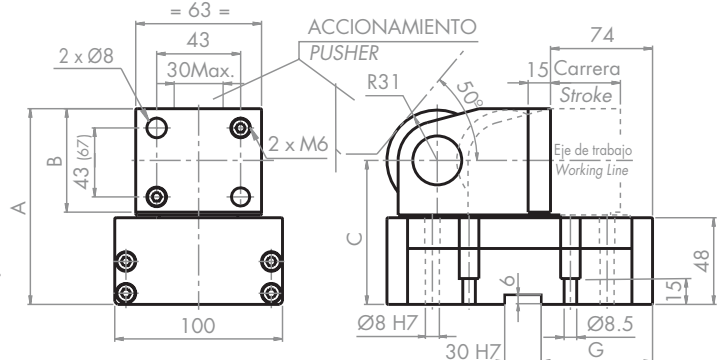

## OCX-R / OCT-R

INCLINACIONES MAXIMAS  
MAXIMUM ANGLE OF INCLINATION

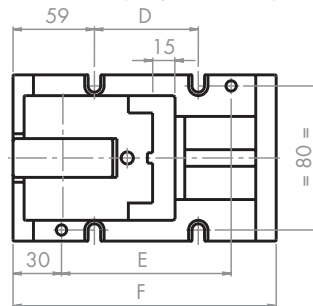
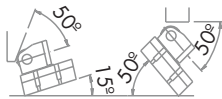

### CARRO CON CABEZAL EN "U" PARA AMARRE LATERAL. ESTE AMARRE PERMITE DESMONTAR EL CABEZAL SIN SOLTAR EL PUNZON.

CAM WITH "U" SHAPES SIDE FASTENING. THIS FASTENING ALLOWS HEAD DISSASSEMBLING WITH PUNCH MOUNTED.

MODELO DE CARRO CAM MODEL	Carrera máx. recomendada Recommended max. stroke	A	B	C	D	E	F	G	Cilindro Spring
OCX.03.50	50	117	63	86	76	134	190	78	APF 150 x 63.5
OCT.03.50									CT 300 x 63
OCX.03.80	72	117	63	86	106	164	220	108	APF 150 x 80
OCT.03.80									CT 300 x 80
OCX.03.100	90	141	87	110	146	204	260	148	APF 150 x 100
OCT.03.100									CT 300 x 100

MODELO DE CARRO CAM MODEL	Fuerza máxima de punzonado (daN) Maximum punching force (daN)	Fuerza de retroceso (daN) Backward force (daN)	Nº de tornillos del cabezal No. of screws on front
OCX.03.50	3000	150	2
OCT.03.50			
OCX.03.80		300	
OCT.03.80			
OCX.03.100			
OCT.03.100			

### EJEMPLO DE PEDIDO / ORDER EXAMPLE

OCX 03 - 80

Modelo  
Model

+ Fuerza Tm.  
+ Force Tm.

Tipo  
Type

Se recomienda una reserva del 10% de la carrera.  
Azol-Gas se reserva el derecho a efectuar cambios de diseño.

A 10% stroke length allowance is recommended.  
Azol-Gas keeps its right to make any desing modification.

# CARRO OCX.05 OCX.05 ROLLER CAM

## OCX / OCT

**CARRO CON CABEZAL PLANO DE AMARRE FRONTAL.**

**CAM WITH FRONT FASTENING FLAT HEAD.**

Cotas entre ( ), para carros de carrera 100.

Dimensions in ( ), for 100 stroke cam.

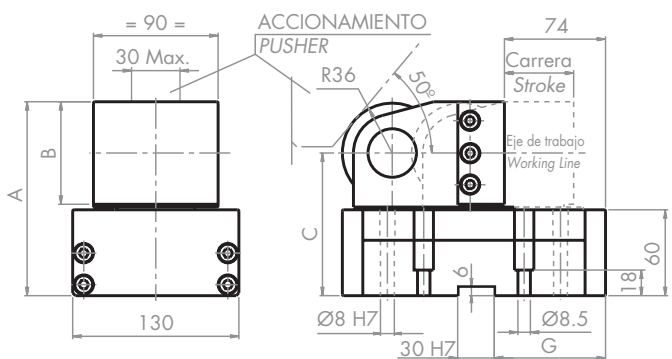
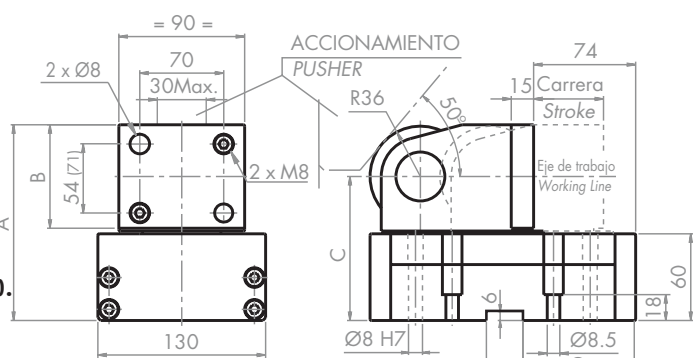

## OCX-R / OCT-R

**INCLINACIONES MAXIMAS  
MAXIMUM ANGLE OF INCLINATION**

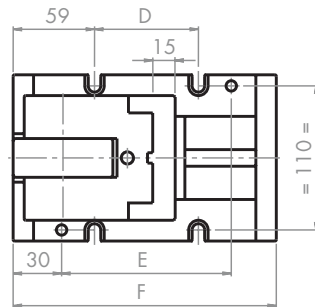
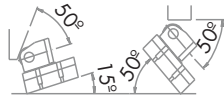

**CARRO CON CABEZAL EN "U" PARA AMARRE LATERAL. ESTE AMARRE PERMITE DESMONTAR EL CABEZAL SIN SOLTAR EL PUNZON.**

**CAM WITH "U" SHAPES SIDE FASTENING. THIS FASTENING ALLOWS HEAD DISSASSEMBLING WITH PUNCH MOUNTED.**

MODELO DE CARRO CAM MODEL	Carrera máx. recomendada Recommended max. stroke	A	B	C	D	E	F	G	Cilindro Spring
OCX.05.50 OCT.05.50	50	140	74	103	76	134	190	78	APF 150 x 63.5 CT 300 x 63
OCX.05.80 OCT.05.80	72	140	74	103	106	164	220	108	APF 150 x 80 CT 300 x 80
OCX.05.100 OCT.05.100	90	157	91	120	146	204	260	148	APF 150 x 100 CT 300 x 100

MODELO DE CARRO CAM MODEL	Fuerza máxima de punzonado (daN) Maximum pushing force (daN)	Fuerza de retroceso (daN) Backward force (daN)	Nº de tornillos del cabezal No. of screws on front
OCX.05.50 OCT.05.50	5000	150	2
OCX.05.80 OCT.05.80			
OCX.05.100 OCT.05.100		300	

### EJEMPLO DE PEDIDO / ORDER EXAMPLE

OCX 05 - 100

Modelo + Fuerza Tm.  
Model + Force Tm.

Tipo  
Type

Se recomienda una reserva del 10% de la carrera. Azol-Gas se reserva el derecho a efectuar cambios de diseño.

A 10% stroke length allowance is recommended. Azol-Gas keeps its right to make any desing modification.

# CARRO OCX.15 OCX.15 ROLLER CAM

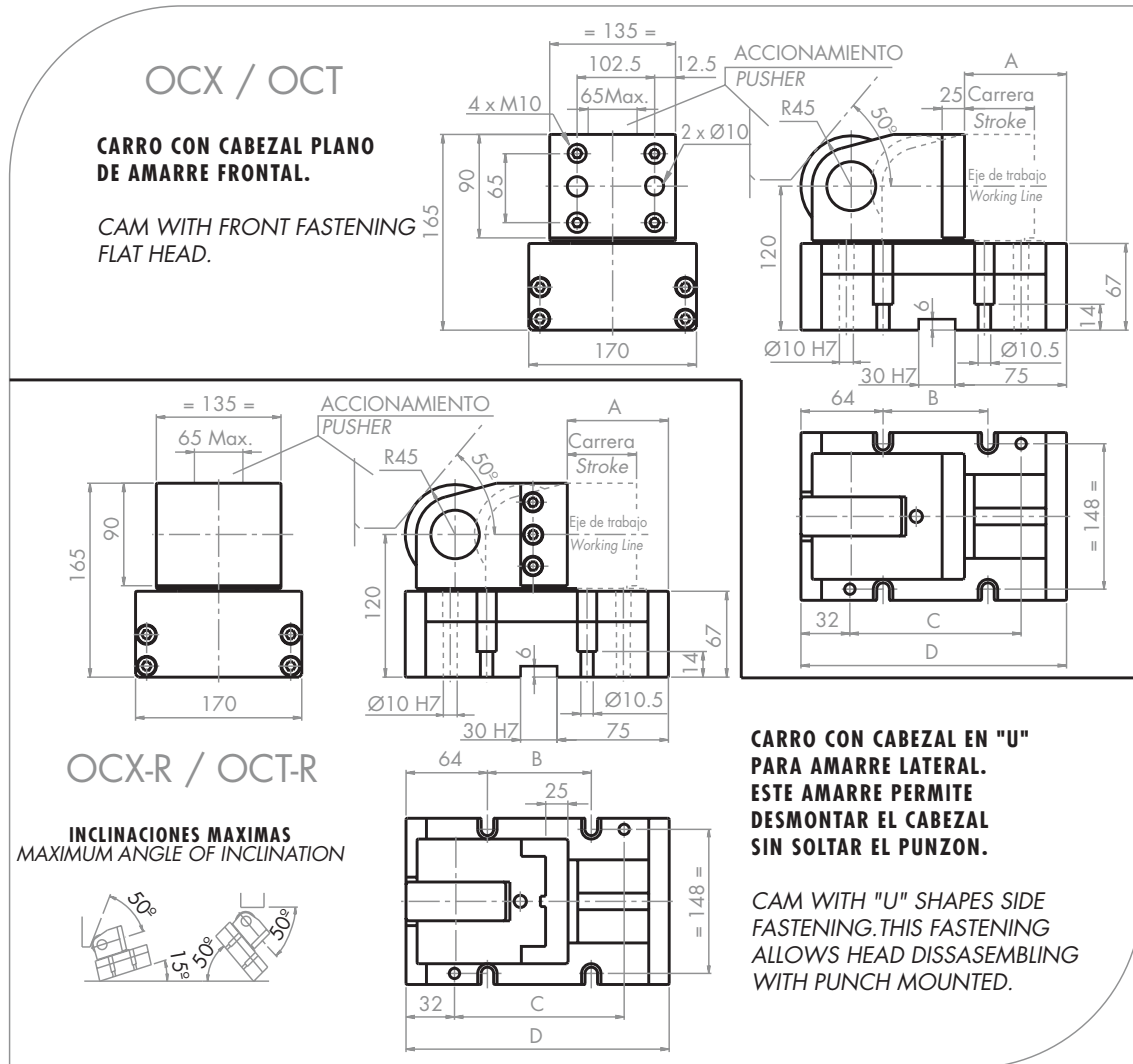

MODELO DE CARRO CAM MODEL	Carrera máx. recomendada Recommended max. stroke	A	B	C	D	Cilindro Spring
OCX.15.50	50	43	67	131	190	APF 250 x 63.5
OCT.15.50						CT 550 x 63
OCX.15.80	72	73	97	161	220	APF 250 x 80
OCT.15.80						CT 550 x 80
OCX.15.100	90	73	137	201	260	APF 250 x 100
OCT.15.100						CT 550 x 100

MODELO DE CARRO CAM MODEL	Fuerza máxima de punzonado (daN) Maximum puching force (daN)	Fuerza de retroceso (daN) Backward force (daN)	Nº de tornillos del cabezal No. of screws on front
OCX.15.50	15000	250	4
OCT.15.50			
OCX.15.80		550	
OCT.15.80			
OCX.15.100			
OCT.15.100			

**EJEMPLO DE PEDIDO / ORDER EXAMPLE**

**OCX 15 - 50**

Modelo + Fuerza Tm.  
Model + Force Tm.

Tipo  
Type

Se recomienda una reserva del 10% de la carrera.  
Azol-Gas se reserva el derecho a efectuar cambios de diseño.

A 10% stroke lenght allowance is recommended.  
Azol-Gas keeps its right to make any desing modification.

# CARRO OCX.20 OCX.20 ROLLER CAM

## OCX / OCT

**CARRO CON CABEZAL PLANO DE AMARRE FRONTAL.**

**CAM WITH FRONT FASTENING FLAT HEAD.**

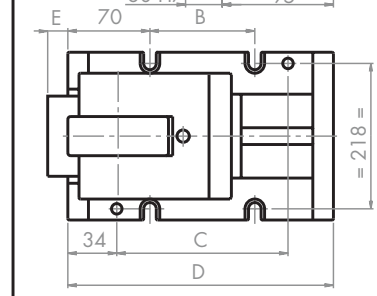
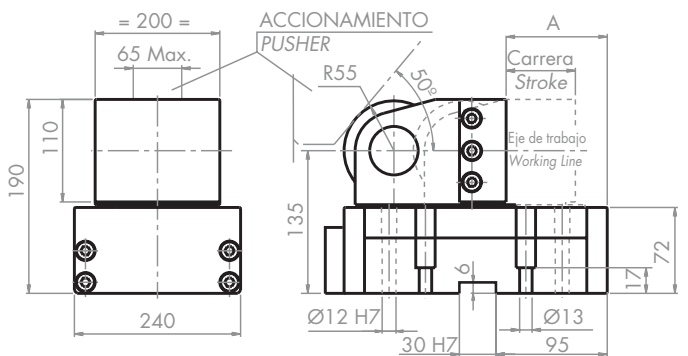
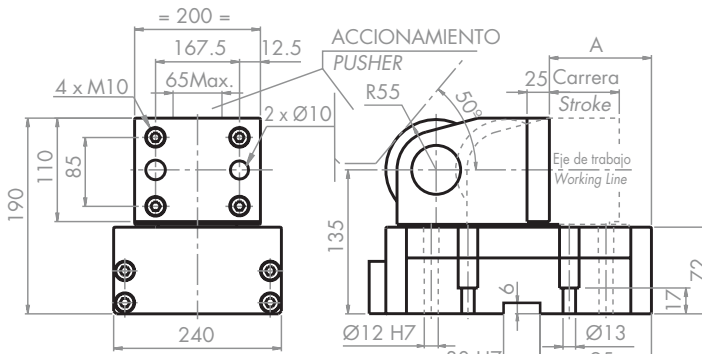

## OCX-R / OCT-R

**INCLINACIONES MAXIMAS  
MAXIMUM ANGLE OF INCLINATION**

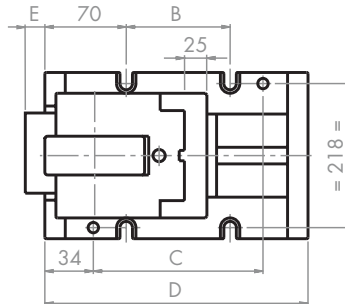

**CARRO CON CABEZAL EN "U"  
PARA AMARRE LATERAL.  
ESTE AMARRE PERMITE  
DESMONTAR EL CABEZAL  
SIN SOLTAR EL PUNZON.**

**CAM WITH "U" SHAPES SIDE  
FASTENING. THIS FASTENING  
ALLOWS HEAD DISSASSEMBLING  
WITH PUNCH MOUNTED.**

MODELO DE CARRO CAM MODEL	Carrera máx. recomendada Recommended max. stroke	A	B	C	D	E	Cilindro Spring
OCX.20.50	50	48	80	152	220	7	APF 500 x 63.5
OCT.20.50						0	CTR 750 x 63
OCX.20.80	72	78	110	182	250	10	APF 500 x 80
OCT.20.80						0	CTR 750 x 80
OCX.20.100	90	78	130	202	270	10	APF 500.E1 x 100
OCT.20.100						0	CTR 750 x 100

MODELO DE CARRO CAM MODEL	Fuerza máxima de punzonado (daN) Maximum pushing force (daN)	Fuerza de retroceso (daN) Backward force (daN)	Nº de tornillos del cabezal No. of screws on front
OCX.20.50	20000	500	4
OCT.20.50			
OCX.20.80	20000	500	4
OCT.20.80			
OCX.20.100	20000	750	4
OCT.20.100			

### EJEMPLO DE PEDIDO / ORDER EXAMPLE

OCX 20 - 80

Modelo + Fuerza Tm. / Model + Force Tm. / Tipo / Type

Se recomienda una reserva del 10% de la carrera.  
Azol-Gas se reserva el derecho a efectuar cambios de diseño.

A 10% stroke length allowance is recommended.  
Azol-Gas keeps its right to make any desing modification.

# CARRO UCX.05 UCX.05 ROLLER CAM

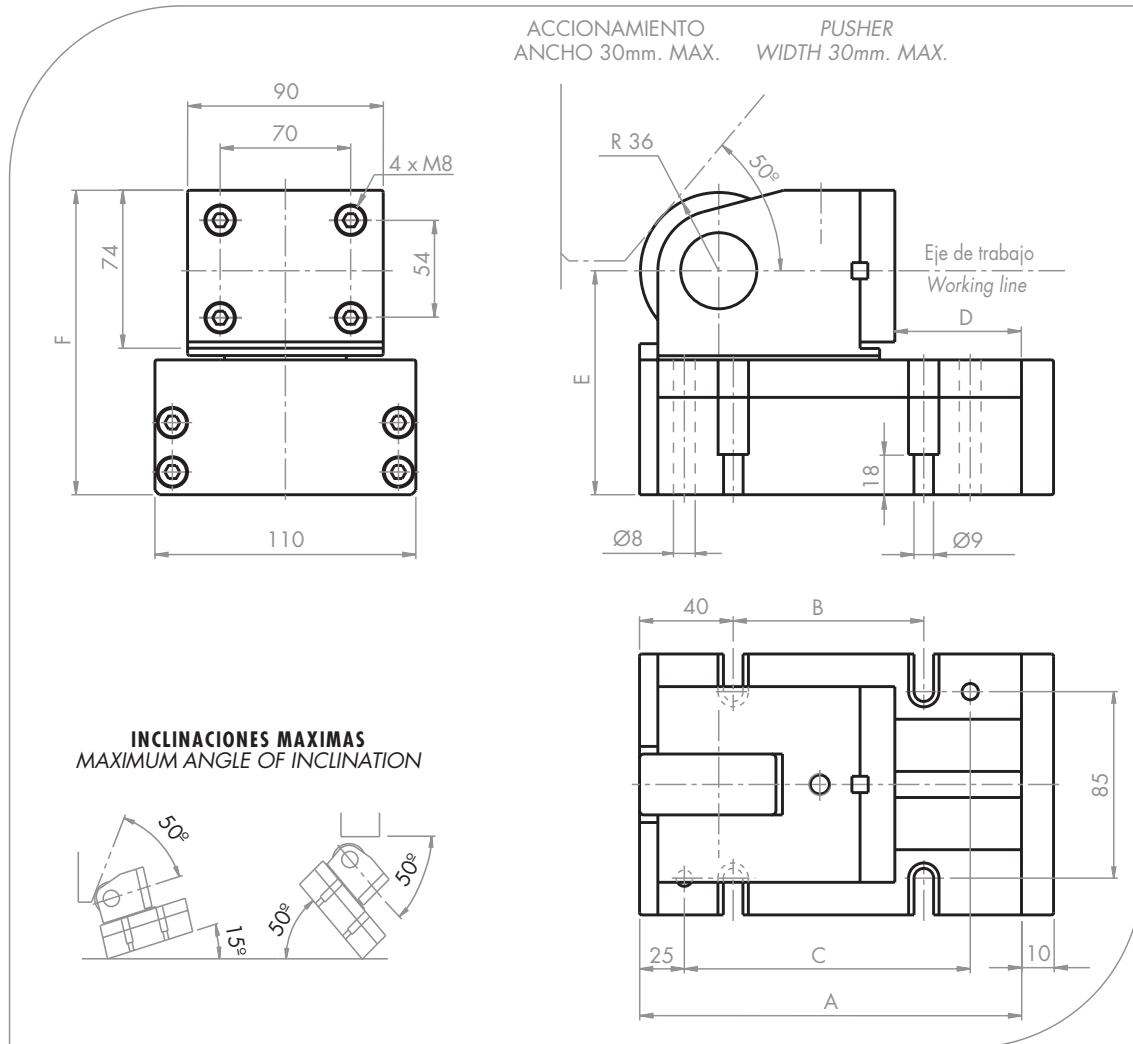

MODELO DE CARRO CAM MODEL	Carrera Stroke	A	B	C	D	E	F	Cilindro Spring
UCX.05.50	50	190	110	140	43	103	140	AFN 150 x 63.5
UCX.05.80	80	220	140	170	73	103	140	AFN 150 x 80
UCX.05.100	100	260	180	210	102	120	157	AFN 150 x 100

MODELO DE CARRO CAM MODEL	Carrera máx. recomendada Recommended max. stroke	Fuerza máxima de punzonado (daN) Maximum puching force (daN)	Fuerza de retroceso (daN) Backward force (daN)
UCX.05.50	50	5000	150
UCX.05.80	72		
UCX.05.100	90		

### EJEMPLO DE PEDIDO / ORDER EXAMPLE

UCX 05 - 50

Modelo + Fuerza Tm.  
Model + Force Tm.

Tipo  
Type

Se recomienda una reserva del 10% de la carrera.  
Azol-Gas se reserva el derecho a efectuar cambios de diseño.

A 10% stroke lenght allowance is recommended.  
Azol-Gas keeps its right to make any desing modification.



# CARRO UCX.15 UCX.15 ROLLER CAM

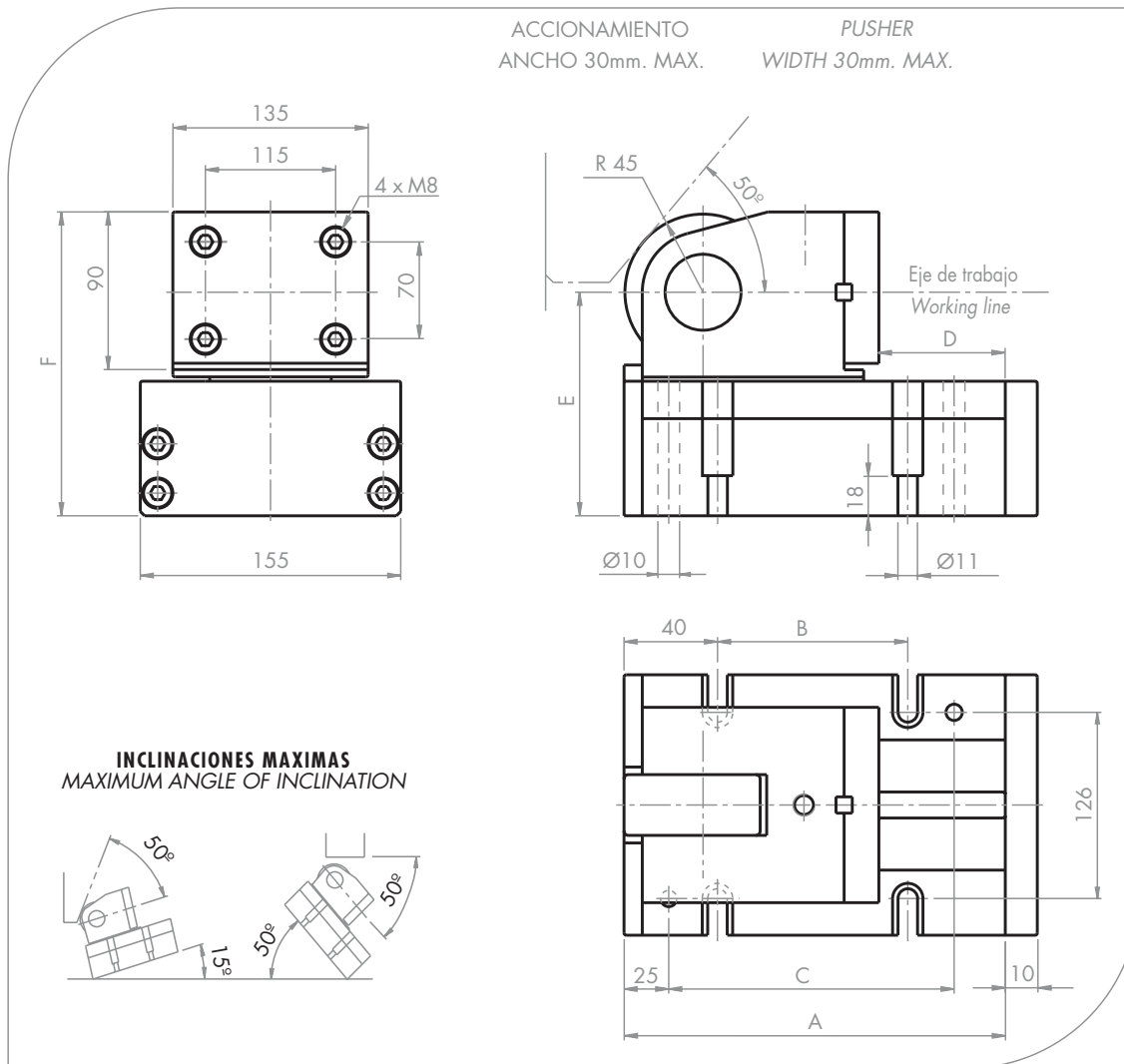

MODELO DE CARRO CAM MODEL	Carrera Stroke	A	B	C	D	E	F	Cilindro Spring
UCX.15.50	50	190	110	140	43	115	160	APF 150 x 63.5
UCX.15.80	80	220	140	170	73	115	160	APF 150 x 80
UCX.15.100	100	260	180	210	93	132	177	APF 150 x 100

MODELO DE CARRO CAM MODEL	Carrera máx. recomendada Recommended max. stroke	Fuerza máxima de punzonado (daN) Maximum puching force (daN)	Fuerza de retroceso (daN) Backward force (daN)
UCX.15.50	50	15000	150
UCX.15.80	72		
UCX.15.100	90		

### EJEMPLO DE PEDIDO / ORDER EXAMPLE

UCX 15 - 100

Modelo + Fuerza Tm.  
Model + Force Tm.

Tipo  
Type

Se recomienda una reserva del 10% de la carrera.  
Azol-Gas se reserva el derecho a efectuar cambios de diseño.

A 10% stroke lenght allowance is recommended.  
Azol-Gas keeps its right to make any desing modification.

# CARRO UCX.20 UCX.20 ROLLER CAM

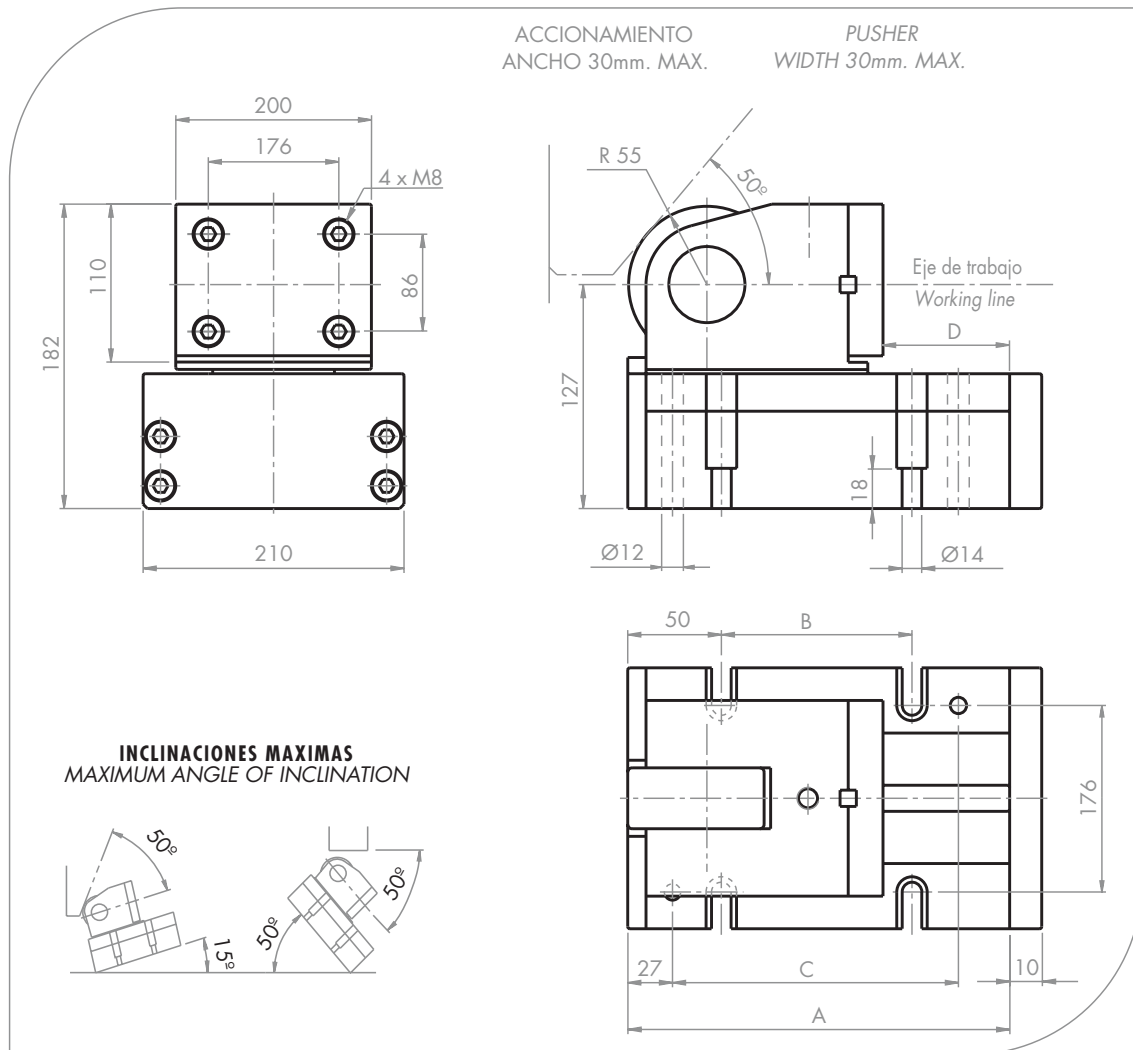

**INCLINACIONES MAXIMAS**  
MAXIMUM ANGLE OF INCLINATION

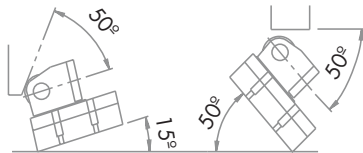

MODELO DE CARRO CAM MODEL	Carrera Stroke	A	B	C	D	Cilindro Spring
<b>UCX.20.50</b>	50	215	115	161	43	APF 250 x 63.5
<b>UCX.20.80</b>	80	245	145	191	73	APF 250 x 80
<b>UCX.20.100</b>	100	265	165	211	93	APF 250 x 100

MODELO DE CARRO CAM MODEL	Carrera máx. recomendada Recommended max. stroke	Fuerza máxima de punzonado (daN) Maximum pushing force (daN)	Fuerza de retroceso (daN) Backward force (daN)
<b>UCX.20.50</b>	50	20000	250
<b>UCX.20.80</b>	72		
<b>UCX.20.100</b>	90		

### EJEMPLO DE PEDIDO / ORDER EXAMPLE

**UCX 20 - 80**

Modelo + Fuerza Tm.  
Model + Force Tm.

Tipo  
Type

Se recomienda una reserva del 10% de la carrera.  
Azol-Gas se reserva el derecho a efectuar cambios de diseño.

A 10% stroke length allowance is recommended.  
Azol-Gas keeps its right to make any desing modification.

# CARRO RCX.03 RCX.03 ROLLER CAM

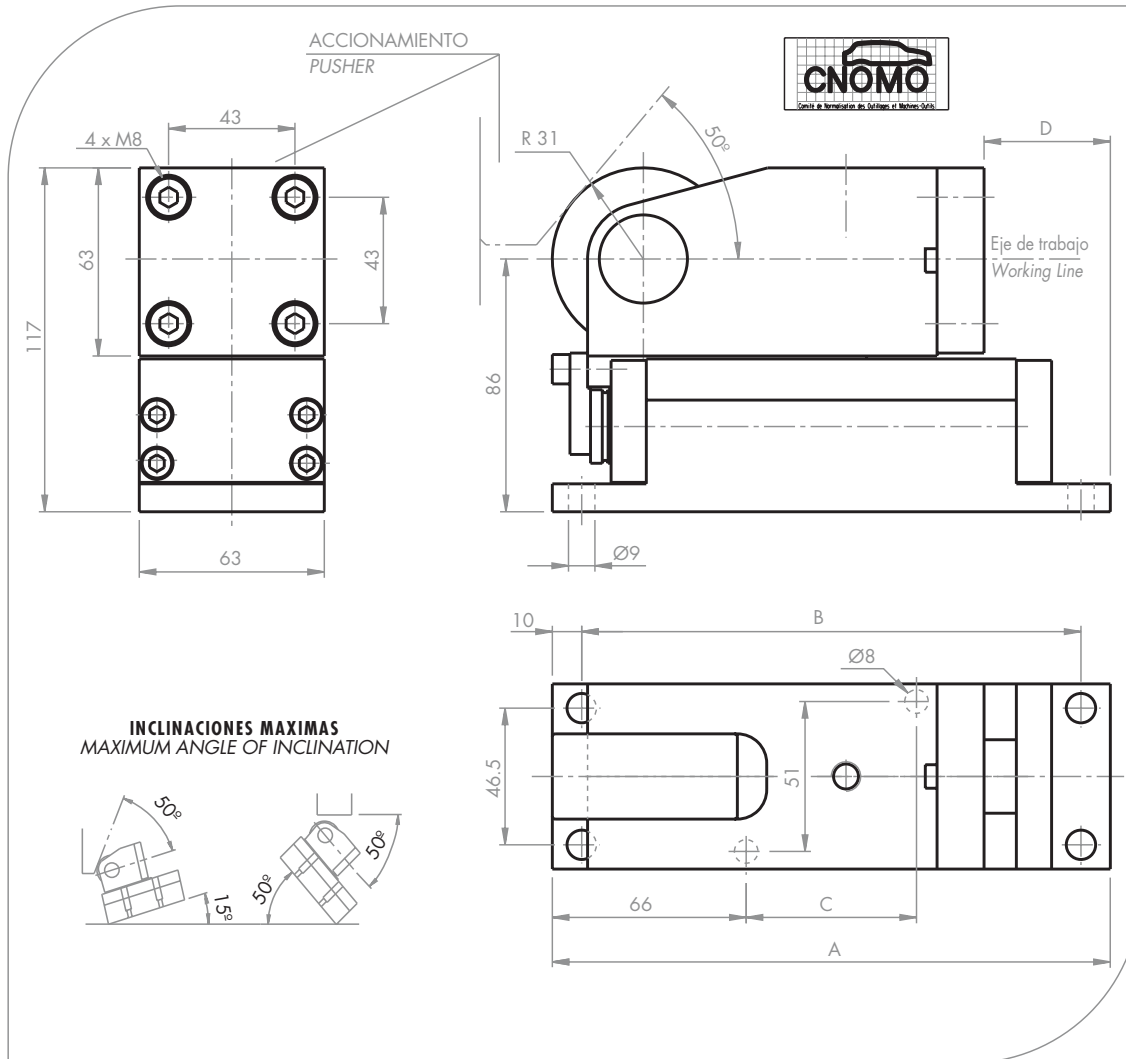

MODELO DE CARRO CAM MODEL	Carrera Stroke	A	B	C	D
RCX.03.50	50	190	170	58	43
RCX.03.80	80	220	200	88	73

MODELO DE CARRO CAM MODEL	Carrera máx. recomendada Recommended max. stroke	Fuerza máxima de punzonado (daN) Maximum puching force (daN)	Fuerza de retroceso (daN) Backward force (daN)
RCX.03.50	45	3000	100
RCX.03.80	72		

### EJEMPLO DE PEDIDO / ORDER EXAMPLE



Se recomienda una reserva del 10% de la carrera.  
Azol-Gas se reserva el derecho a efectuar cambios de diseño.

A 10% stroke lenght allowance is recommended.  
Azol-Gas keeps its right to make any desing modification.

# CARRO RCX.05 RCX.05 ROLLER CAM

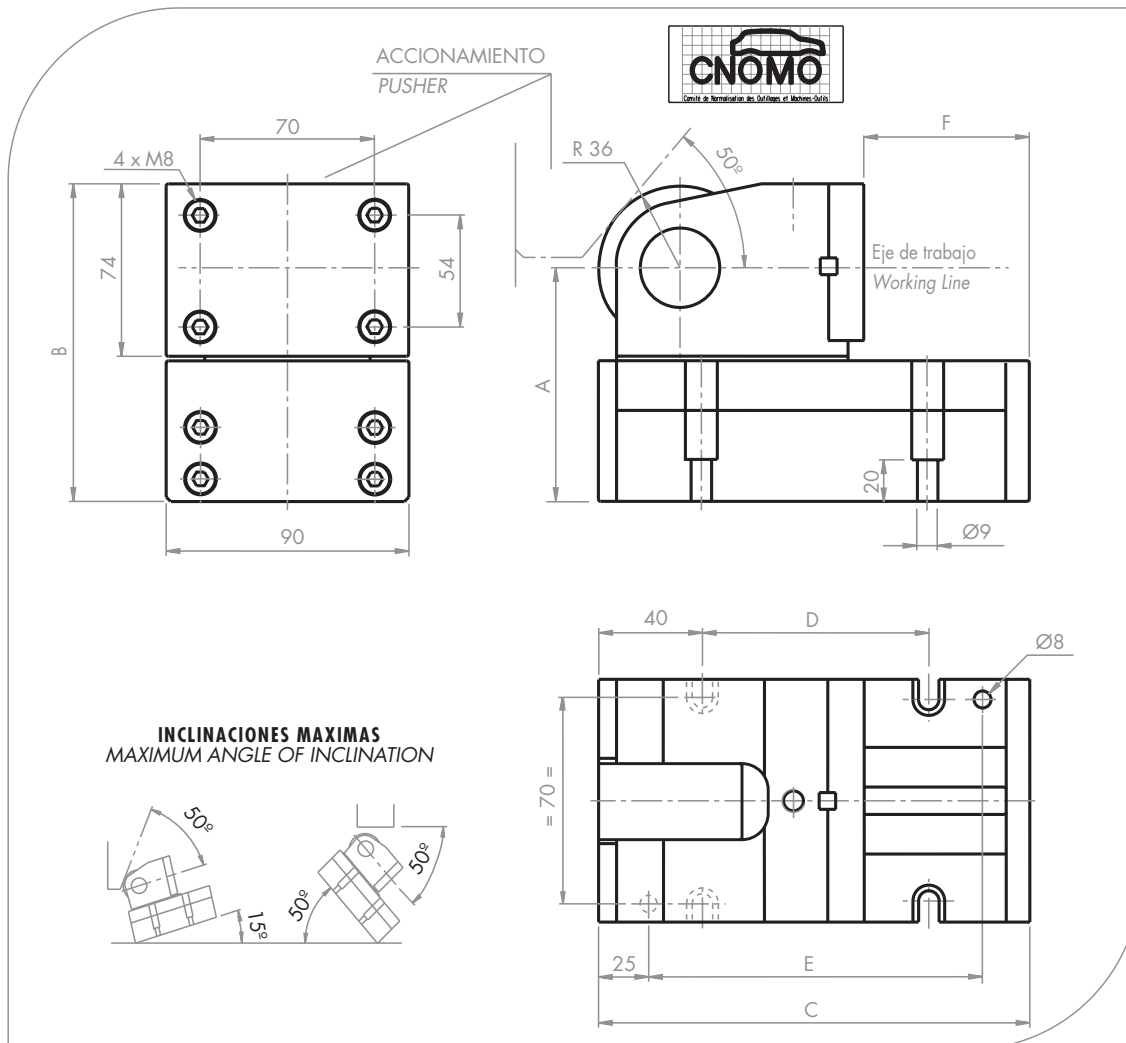

MODELO DE CARRO CAM MODEL	Carrera Stroke	A	B	C	D	E	F
RCX.05.50	50	103	140	190	110	140	43
RCX.05.80	80	103	140	220	140	170	73
RCX.05.100	100	120	157	260	180	210	102

MODELO DE CARRO CAM MODEL	Carrera máx. recomendada Recommended max. stroke	Fuerza máxima de punzonado (daN) Maximum puching force (daN)	Fuerza de retroceso (daN) Backward force (daN)
RCX.05.50	45	5000	100
RCX.05.80	72		
RCX.05.100	90		

### EJEMPLO DE PEDIDO / ORDER EXAMPLE

Modelo + Fuerza Tm. Tipo  
Model + Force Tm. Type

RCX 05 - 80

Se recomienda una reserva del 10% de la carrera.  
Azol-Gas se reserva el derecho a efectuar cambios de diseño.

A 10% stroke lenght allowance is recommended.  
Azol-Gas keeps its right to make any desing modification.

# CARRO RCX.15 RCX.15 ROLLER CAM

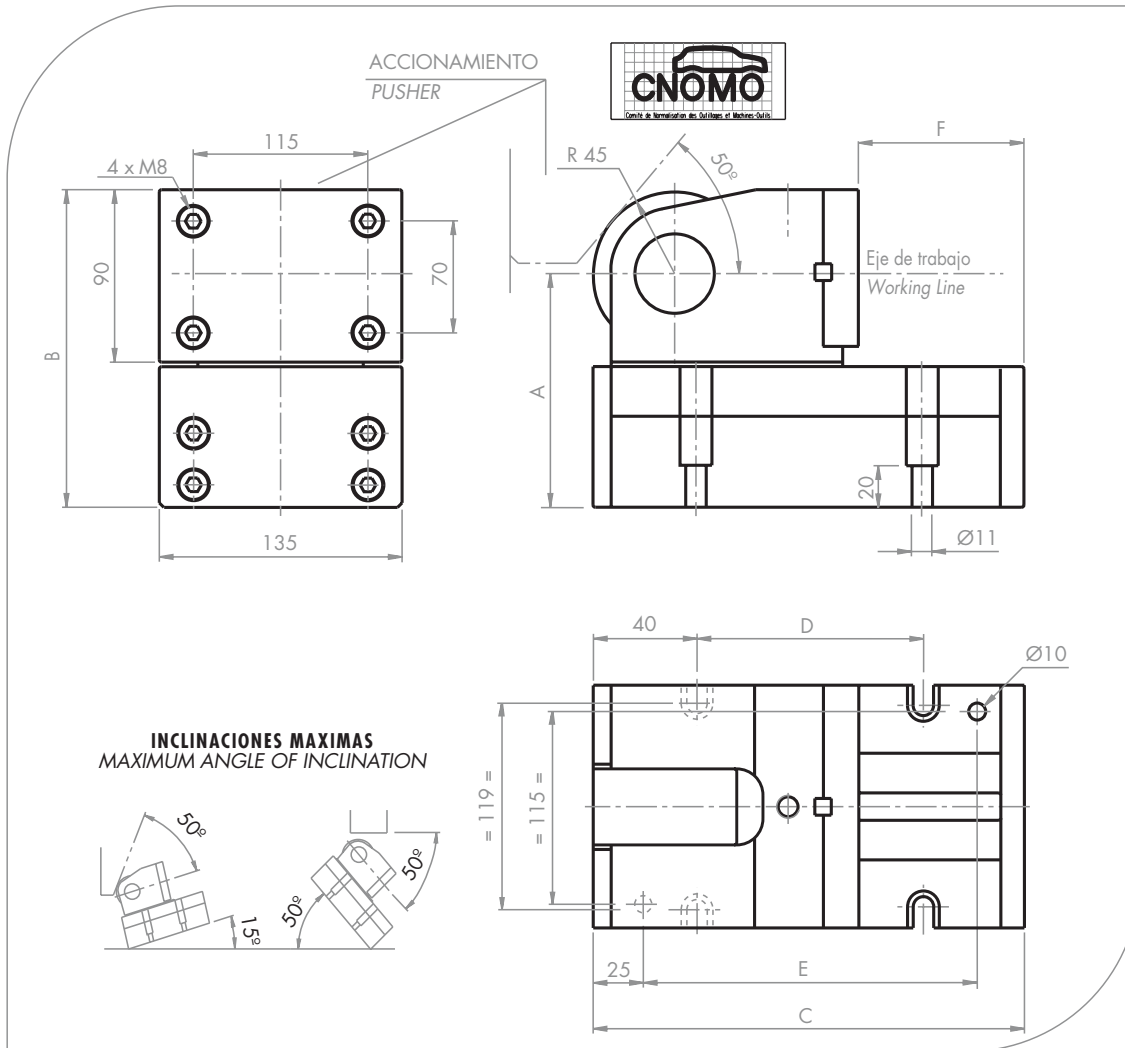

**INCLINACIONES MAXIMAS**  
MAXIMUM ANGLE OF INCLINATION

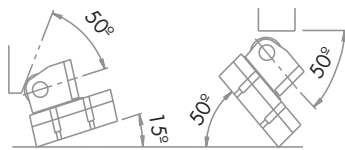

MODELO DE CARRO CAM MODEL	Carrera Stroke	A	B	C	D	E	F
RCX.15.50	50	115	160	190	110	140	43
RCX.15.80	80	115	160	220	140	170	73
RCX.15.100	100	132	177	260	180	210	93

MODELO DE CARRO CAM MODEL	Carrera máx. recomendada Recommended max. stroke	Fuerza máxima de punzonado (daN) Maximum puching force (daN)	Fuerza de retroceso (daN) Backward force (daN)
RCX.15.50	45	15000	150
RCX.15.80	72		
RCX.15.100	90		

### EJEMPLO DE PEDIDO / ORDER EXAMPLE

RCX 15 - 100

Modelo  
Model + Fuerza Tm.  
Force Tm.

Tipo  
Type

Se recomienda una reserva del 10% de la carrera.  
Azol-Gas se reserva el derecho a efectuar cambios de diseño.

A 10% stroke lenght allowance is recommended.  
Azol-Gas keeps its right to make any desing modification.

# CARRO RCX.20 RCX.20 ROLLER CAM

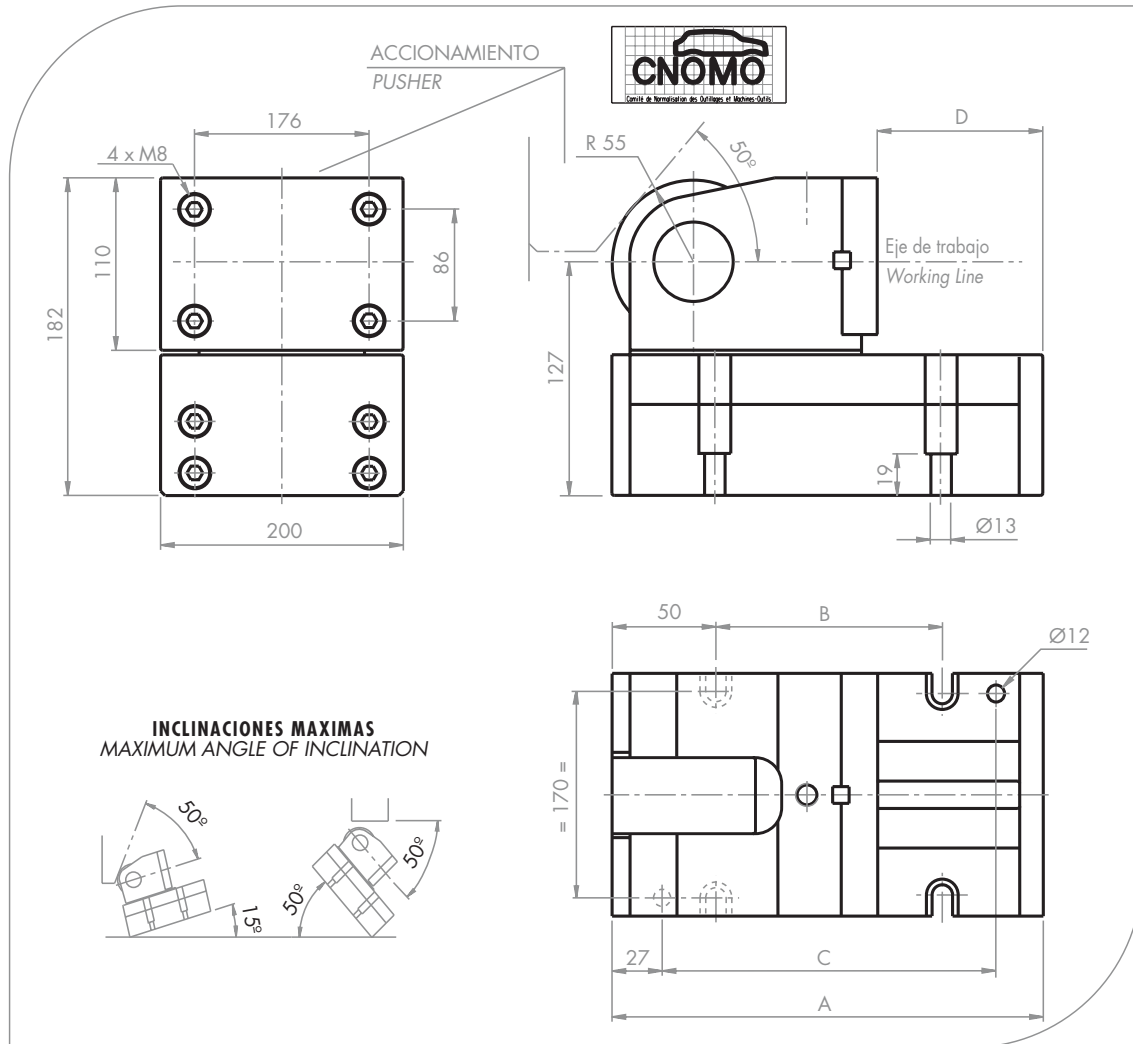

MODELO DE CARRO CAM MODEL	Carrera Stroke	A	B	C	D
<b>RCX.20.50</b>	50	215	115	161	43
<b>RCX.20.80</b>	80	245	145	191	73
<b>RCX.20.100</b>	100	265	165	211	93

MODELO DE CARRO CAM MODEL	Carrera máx. recomendada Recommended max. stroke	Fuerza máxima de punzonado (daN) Maximum punching force (daN)	Fuerza de retroceso (daN) Backward force (daN)
<b>RCX.20.50</b>	45	20000	250
<b>RCX.20.80</b>	72		
<b>RCX.20.100</b>	90		

**EJEMPLO DE PEDIDO / ORDER EXAMPLE**

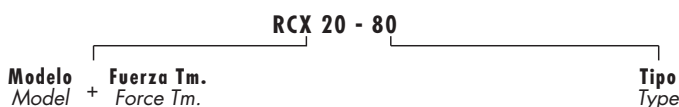

Se recomienda una reserva del 10% de la carrera.  
Azol-Gas se reserva el derecho a efectuar cambios de diseño.

A 10% stroke length allowance is recommended.  
Azol-Gas keeps its right to make any desing modification.

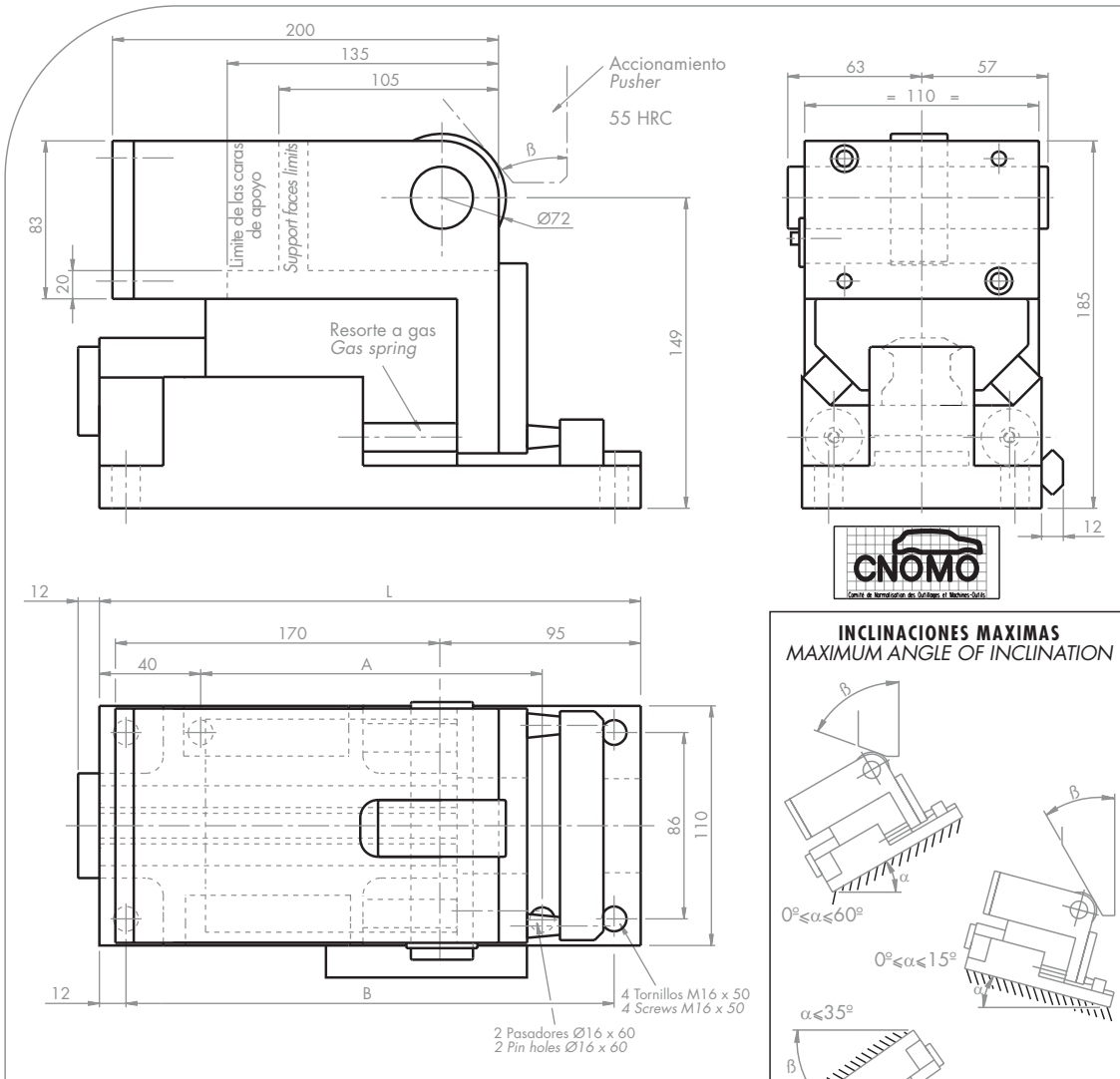

-Si  $\alpha \leq 35^\circ$  adaptar una placa de poliamida a la zona de contacto con la rulina para evitar golpes.

-B En función de  $\alpha$  siguiendo consignas específicas de cada grupo.

-If  $\alpha \leq 35^\circ$  adapt a polyamide plate in the contact surface with the bearing to avoid impacts.

-B In function of  $\alpha$  in following specific consigns of the group.

MODELO DE CARRO CAM MODEL	Carrera Stroke	L	A	B	Fuerza máxima de punzonado (daN) Maximum pushing force (daN)	Fuerza de retroceso (daN) Backward force (daN)
UCK .05 . 50	50	270	190	246	5000	150
UCK . 05 . 80	80	305	265	281		

### EJEMPLO DE PEDIDO / ORDER EXAMPLE

UCK 05 - 80

Modelo + Fuerza Tm.  
Model + Force Tm.

Tipo  
Type

Se recomienda una reserva del 10% de la carrera. Azol-Gas se reserva el derecho a efectuar cambios de diseño.

A 10% stroke length allowance is recommended. Azol-Gas keeps its right to make any desing modification.

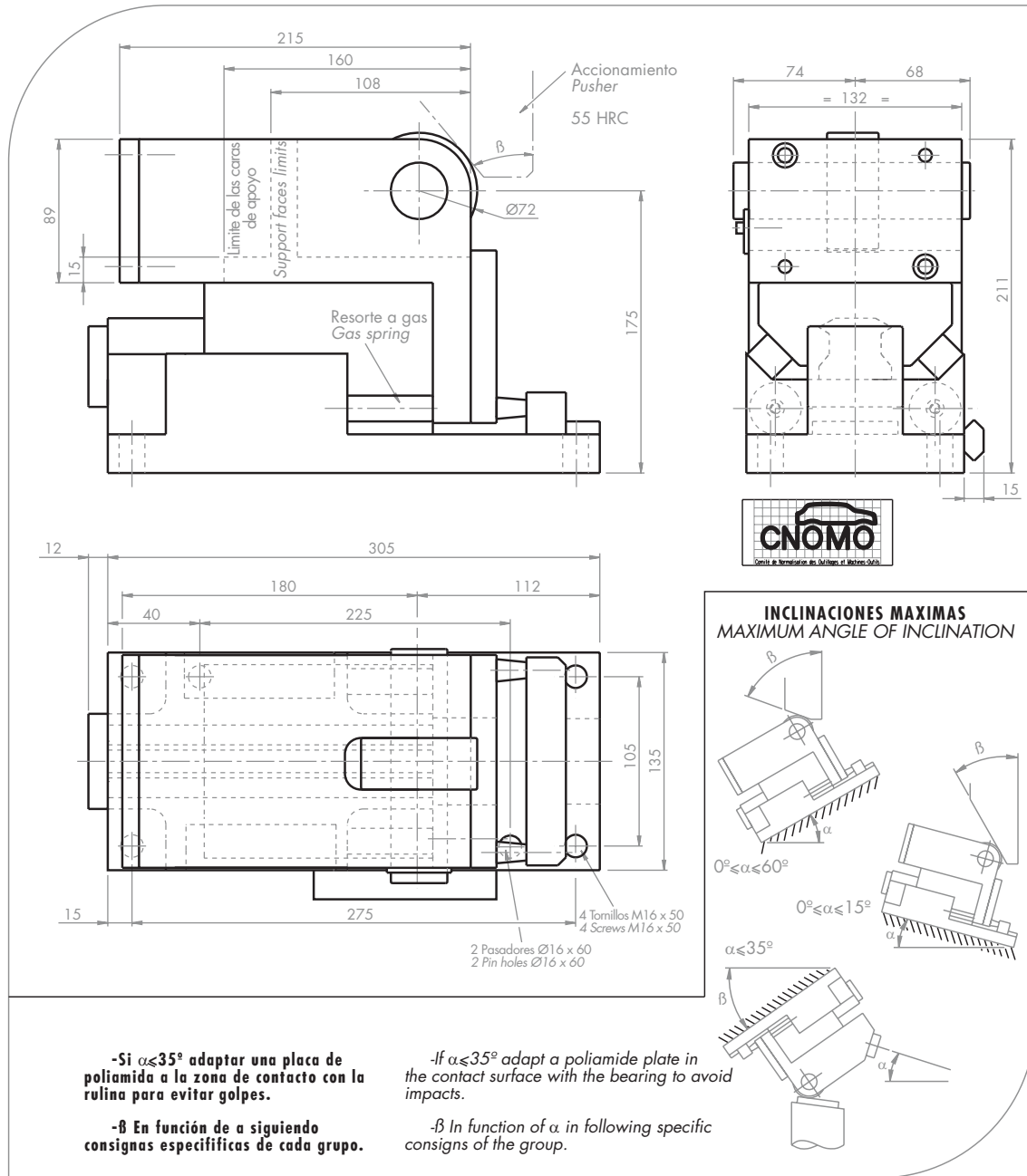

MODELO DE CARRO CAM MODEL	Carrera Stroke	L	A	B	Fuerza máxima de punzonado (daN) Maximum pushing force (daN)	Fuerza de retroceso (daN) Backward force (daN)
UCK .08 . 50	50	270	190	246	8000	250



Se recomienda una reserva del 10% de la carrera.  
Azol-Gas se reserva el derecho a efectuar cambios de diseño.

A 10% stroke length allowance is recommended.  
Azol-Gas keeps its right to make any design modification.



# CARRO UCK.20

## UCK.20 ROLLER CAM

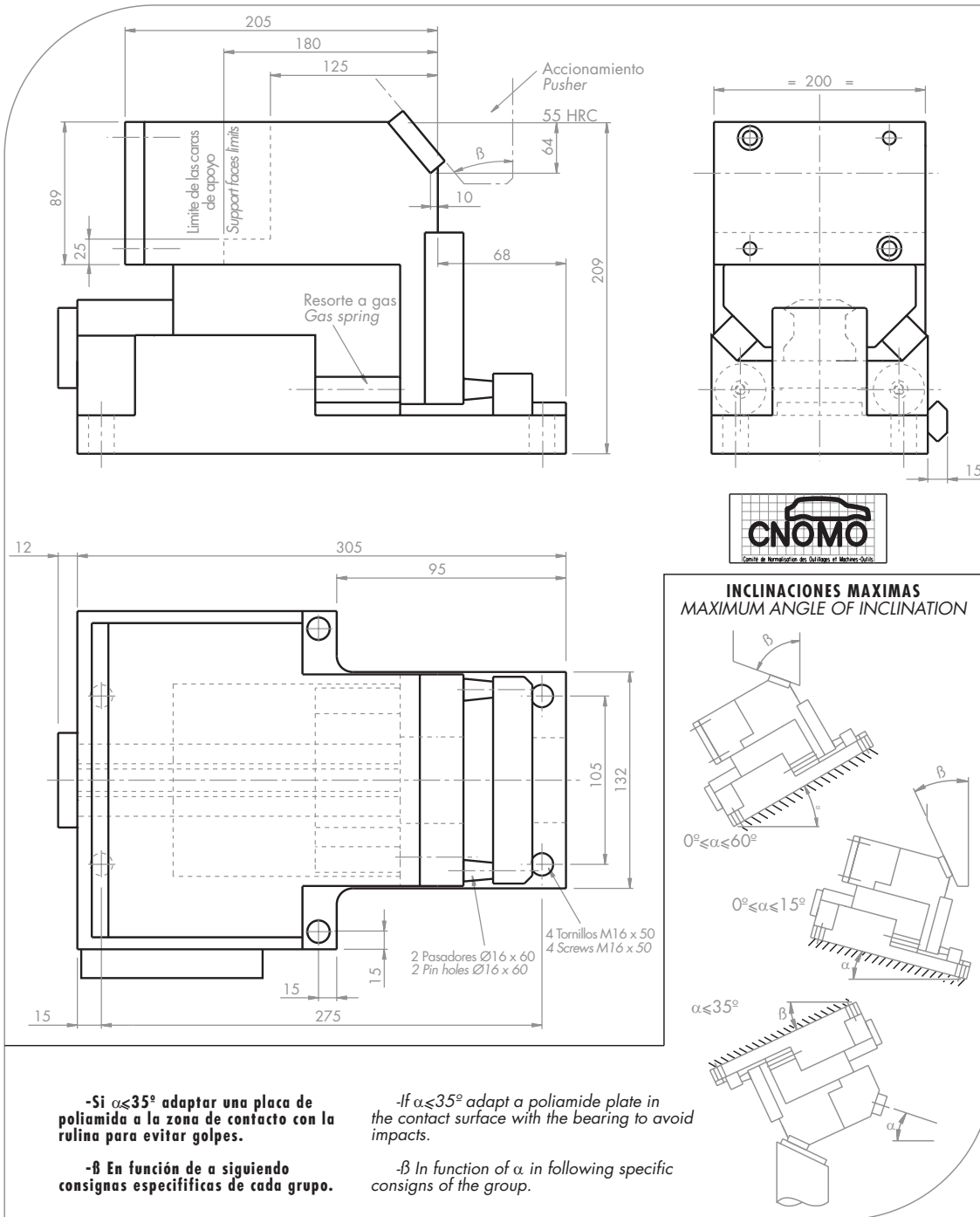

-Si  $\alpha \leq 35^\circ$  adaptar una placa de poliamida a la zona de contacto con la rulina para evitar golpes.

- $\beta$  En función de  $\alpha$  siguiendo consignas específicas de cada grupo.

-If  $\alpha \leq 35^\circ$  adapt a polyamide plate in the contact surface with the bearing to avoid impacts.

- $\beta$  In function of  $\alpha$  in following specific consigns of the group.

MODELO DE CARRO CAM MODEL	Carrera Stroke	Fuerza máxima de punzonado (daN) Maximum puching force (daN)	Fuerza de retroceso (daN) Backward force (daN)
UCK .20 . 50	50	20000	250

### EJEMPLO DE PEDIDO / ORDER EXAMPLE

UCK 20 - 50

Modelo + Fuerza Tm.  
Model + Force Tm.

Tipo  
Type

Se recomienda una reserva del 10% de la carrera.  
Azol-Gas se reserva el derecho a efectuar cambios de diseño.

A 10% stroke length allowance is recommended.  
Azol-Gas keeps its right to make any desing modification.

# CARRO UCX-E.03 UCX-E.03 ROLLER CAM

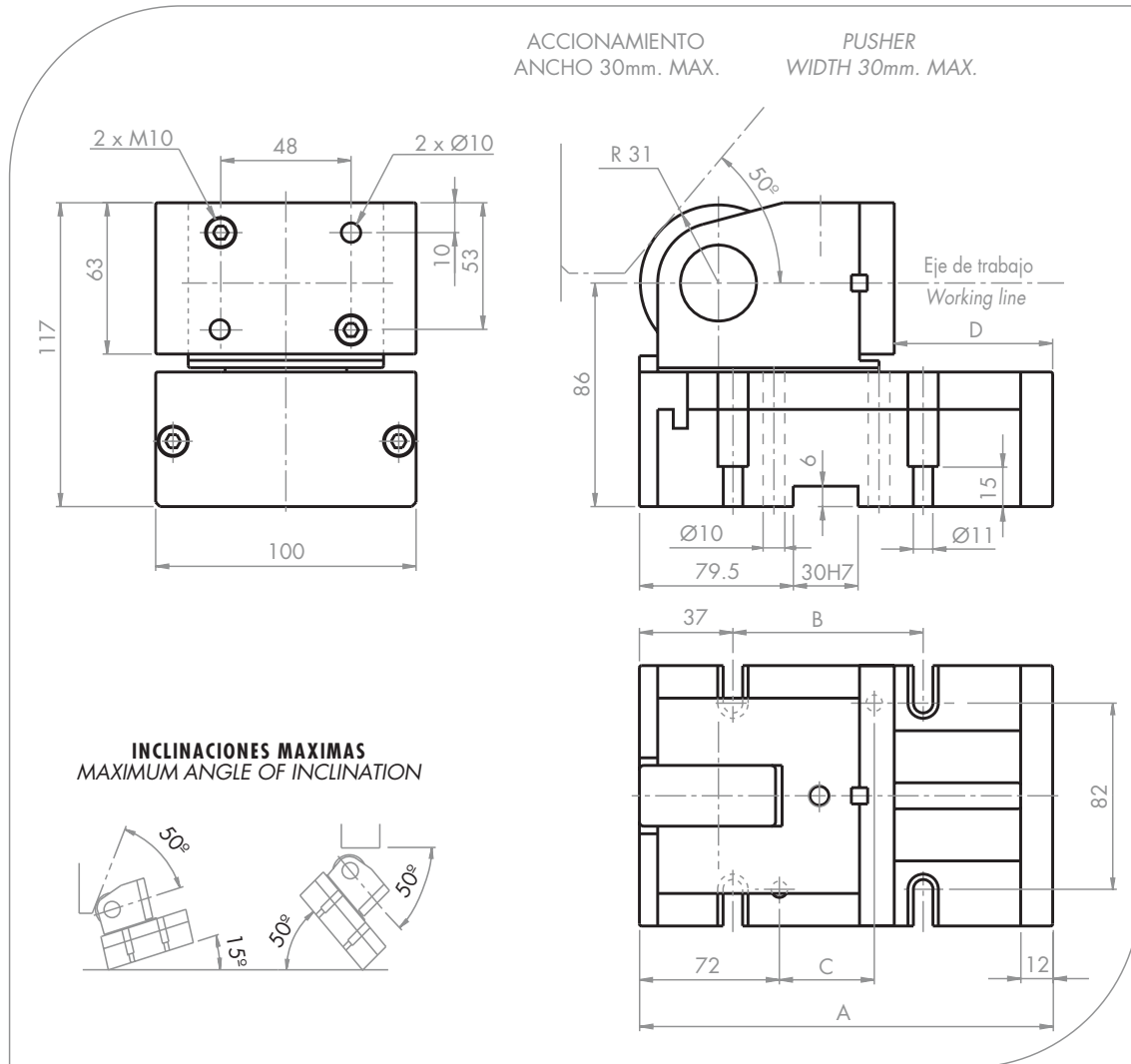

**INCLINACIONES MAXIMAS  
MAXIMUM ANGLE OF INCLINATION**

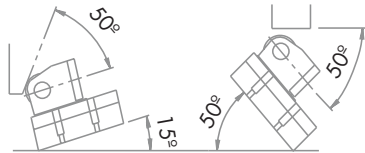

MODELO DE CARRO CAM MODEL	Carrera Stroke	A	B	C	D	Cilindro Spring
UCX-E.03.50	50	190	116	46	43	AFN 150 x 50
UCX-E.03.80	80	220	146	76	73	AFN 150 x 80

MODELO DE CARRO CAM MODEL	Carrera máx. recomendada Recommended max. stroke	Fuerza máxima de punzonado (daN) Maximum puching force (daN)	Fuerza de retroceso (daN) Backward force (daN)
UCX-E.03.50	45	3000	150
UCX-E.03.80	72		

**EJEMPLO DE PEDIDO / ORDER EXAMPLE**

UCX-E 03 - 50

Modelo + Fuerza Tm.  
Model + Force Tm.

Tipo  
Type

Se recomienda una reserva del 10% de la carrera.  
Azol-Gas se reserva el derecho a efectuar cambios de diseño.

A 10% stroke lenght allowance is recommended.  
Azol-Gas keeps its right to make any desing modification.

# CARRO UCX-E.05 UCX-E.05 ROLLER CAM

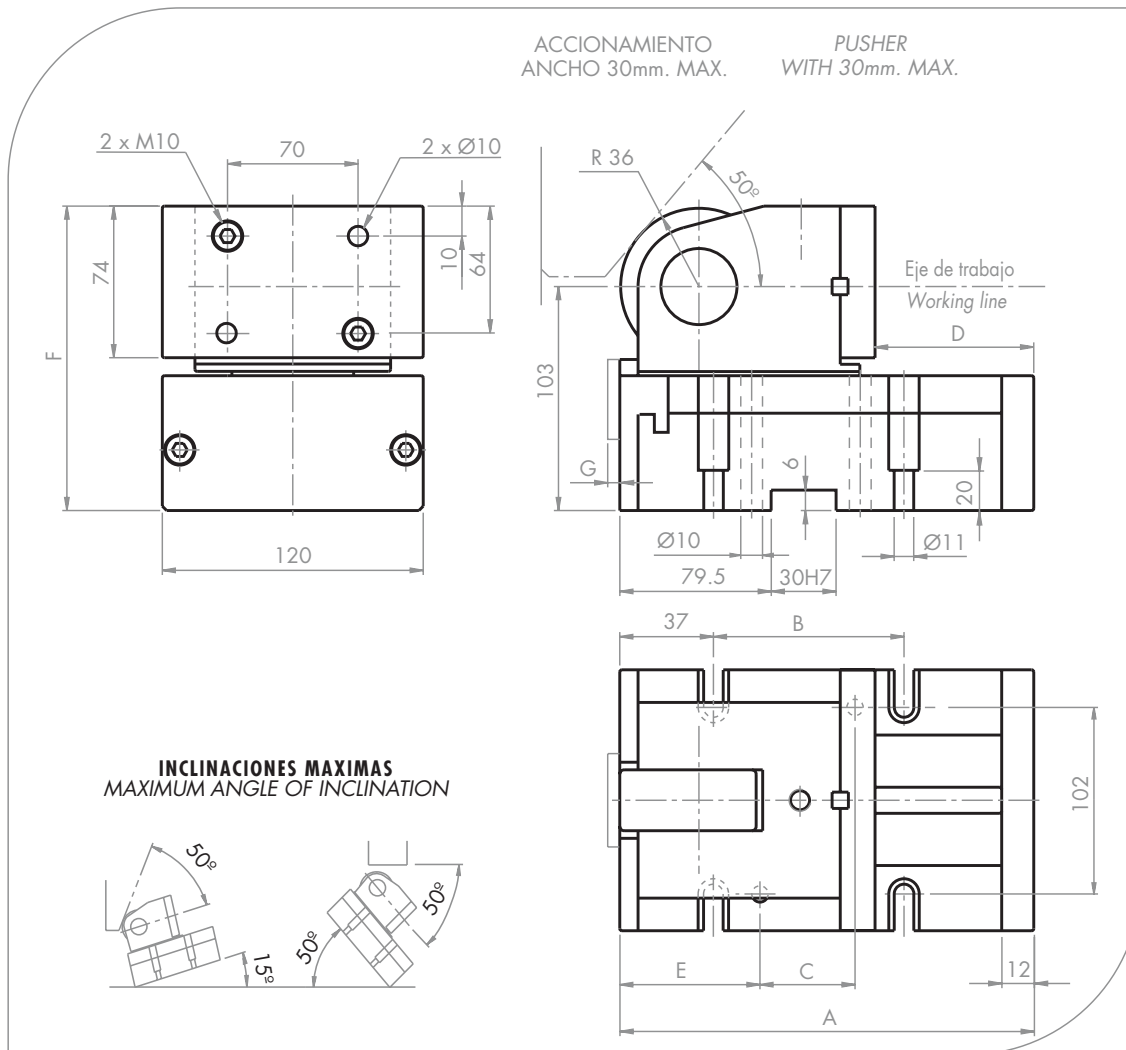

MODELO DE CARRO CAM MODEL	Carrera Stroke	A	B	C	D	E	G	F	Cilindro Spring
UCX-E.05.50	50	190	116	46	43	72	0	140	APF 150 x 50
UCX-E.05.80	80	220	146	76	73	72	2	140	APF 150 x 80
UCX-E.05.100	100	260	166	112	113	74	2	140	APF 150 x 100

MODELO DE CARRO CAM MODEL	Carrera máx. recomendada Recommended max. stroke	Fuerza máxima de punzonado (daN) Maximum puching force (daN)	Fuerza de retroceso (daN) Backward force (daN)
UCX-E.05.50	45	5000	150
UCX-E.05.80	72		
UCX-E.05.100	90		

### EJEMPLO DE PEDIDO / ORDER EXAMPLE

Modelo + Fuerza Tm. Tipo  
 Model + Force Tm. Type

UCX-E 05 - 100

Se recomienda una reserva del 10% de la carrera.  
 Azol-Gas se reserva el derecho a efectuar cambios de diseño.

A 10% stroke lenght allowance is recommended.  
 Azol-Gas keeps its right to make any desing modification.

# CARRO UCX-E.07

## UCX-E.07 ROLLER CAM

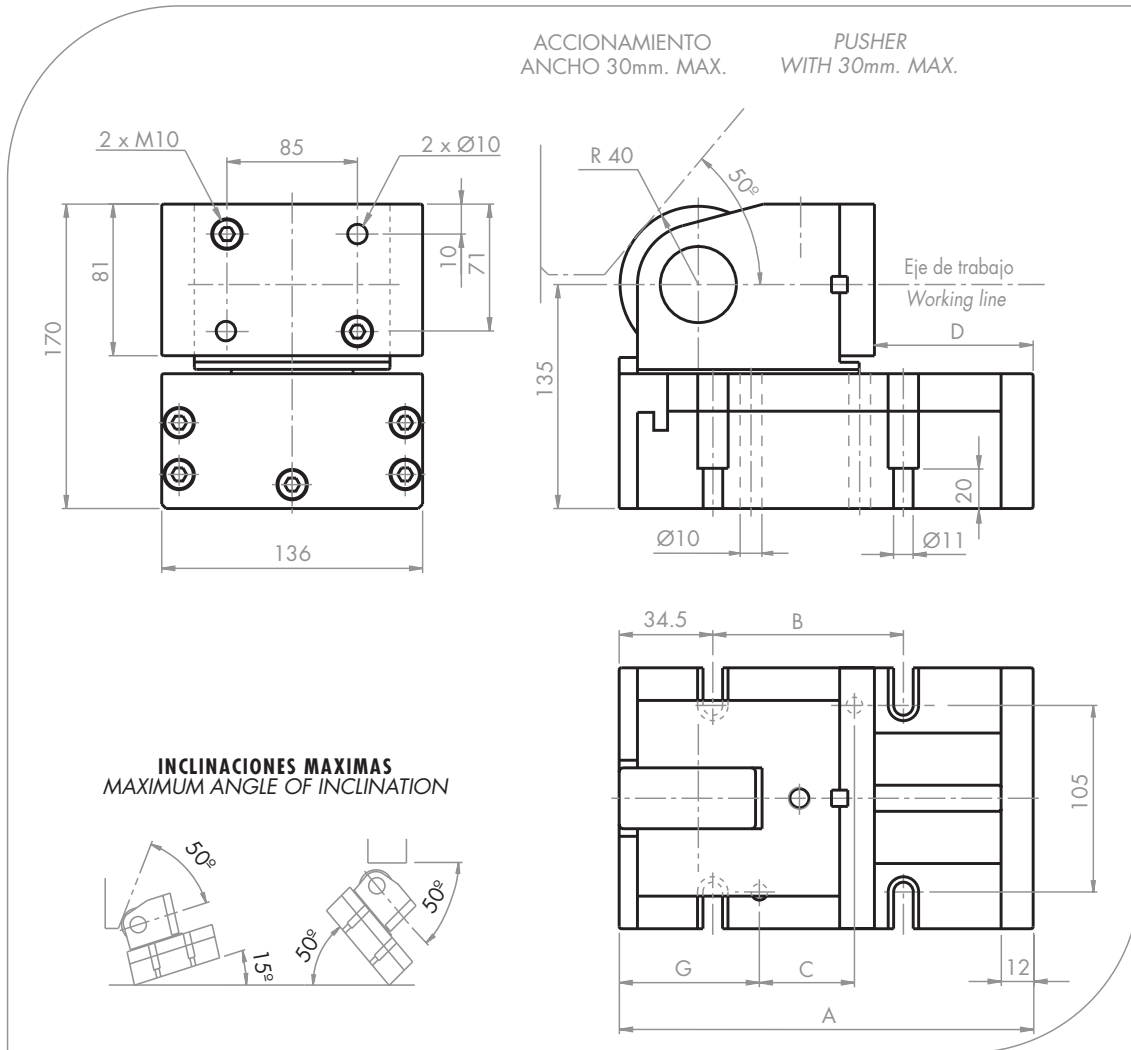

MODELO DE CARRO CAM MODEL	Carrera Stroke	A	B	C	D	G	Cilindro Spring
UCX-E.07.63	63	273	204	140	43.5	66.5	APF 250 x 63
UCX-E.07.80	80	316	247	183	58.5	66.5	APF 250 x 80
UCX-E.07.100	100	366	297	229	86.5	68.5	APF 250 x 100

MODELO DE CARRO CAM MODEL	Carrera máx. recomendada Recommended max. stroke	Fuerza máxima de punzonado (daN) Maximum puching force (daN)	Fuerza de retroceso (daN) Backward force (daN)
UCX-E.07.63	57	7000	250
UCX-E.07.80	72		
UCX-E.07.100	90		

EJEMPLO DE PEDIDO / ORDER EXAMPLE

UCX-E 07 - 100

Modelo + Fuerza Tm.  
Model + Force Tm.

Tipo  
Type

Se recomienda una reserva del 10% de la carrera.  
Azol-Gas se reserva el derecho a efectuar cambios de diseño.

A 10% stroke lenght allowance is recommended.  
Azol-Gas keeps its right to make any desing modification.

# CARRO UCX-E.15 UCX-E.15 ROLLER CAM

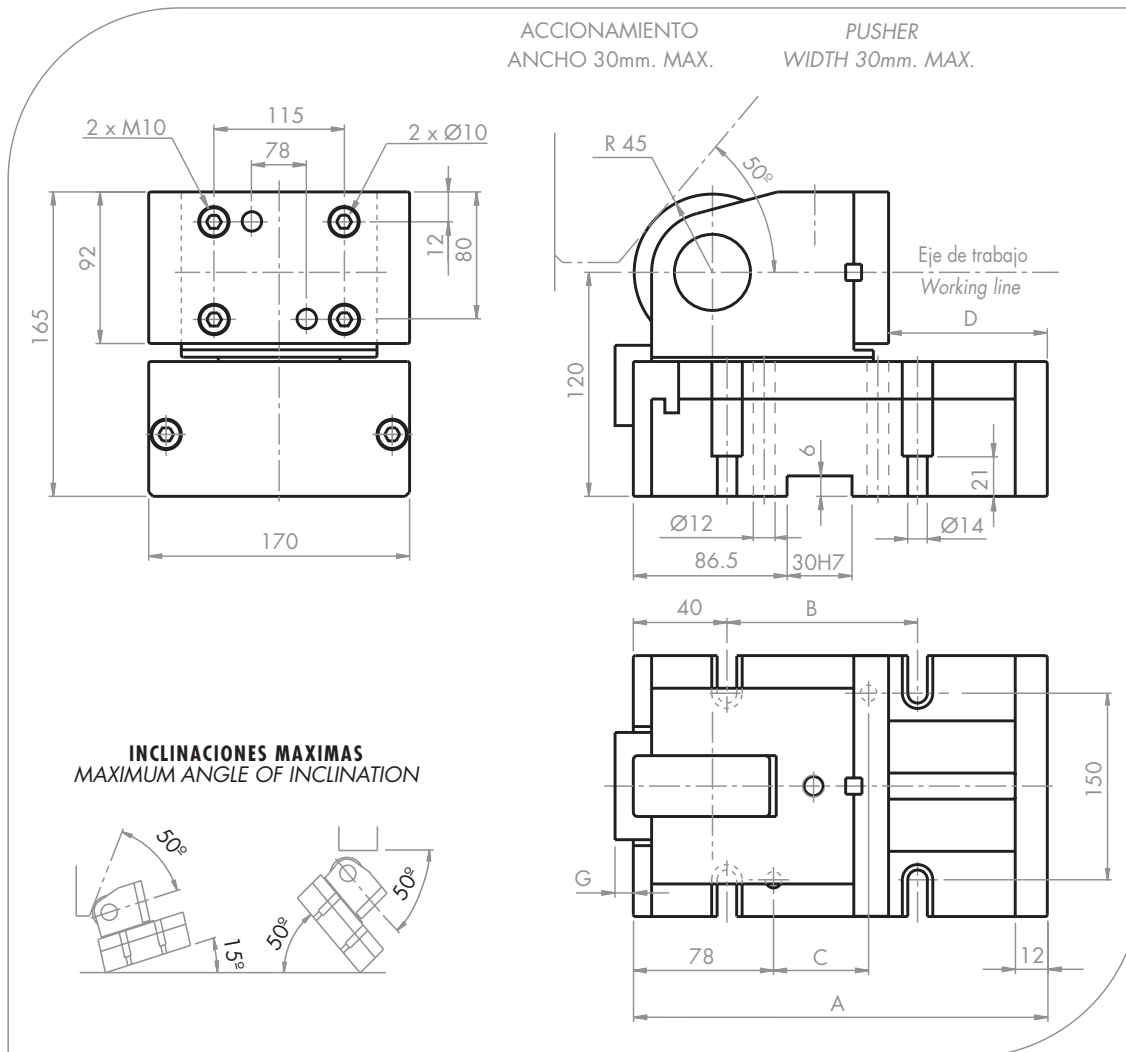

MODELO DE CARRO CAM MODEL	Carrera Stroke	A	B	C	D	G	Cilindro Spring
UCX-E.15.50	50	200	123	47	44	0	APF 250 x 50
UCX-E.15.80	80	230	153	77	74	7.5	APF 250 x 80
UCX-E.15.100	100	250	173	97	94	12	APF 250 x 100

MODELO DE CARRO CAM MODEL	Carrera máx. recomendada Recommended max. stroke	Fuerza máxima de punzonado (daN) Maximum puching force (daN)	Fuerza de retroceso (daN) Backward force (daN)
UCX-E.15.50	45	15000	250
UCX-E.15.80	72		
UCX-E.15.100	90		

### EJEMPLO DE PEDIDO / ORDER EXAMPLE

UCX-E 15 - 80

Modelo + Fuerza Tm.  
Model + Force Tm.

Tipo  
Type

Se recomienda una reserva del 10% de la carrera.  
Azol-Gas se reserva el derecho a efectuar cambios de diseño.

A 10% stroke lenght allowance is recommended.  
Azol-Gas keeps its right to make any desing modification.

# CARRO UCX-E.20

## UCX-E.20 ROLLER CAM

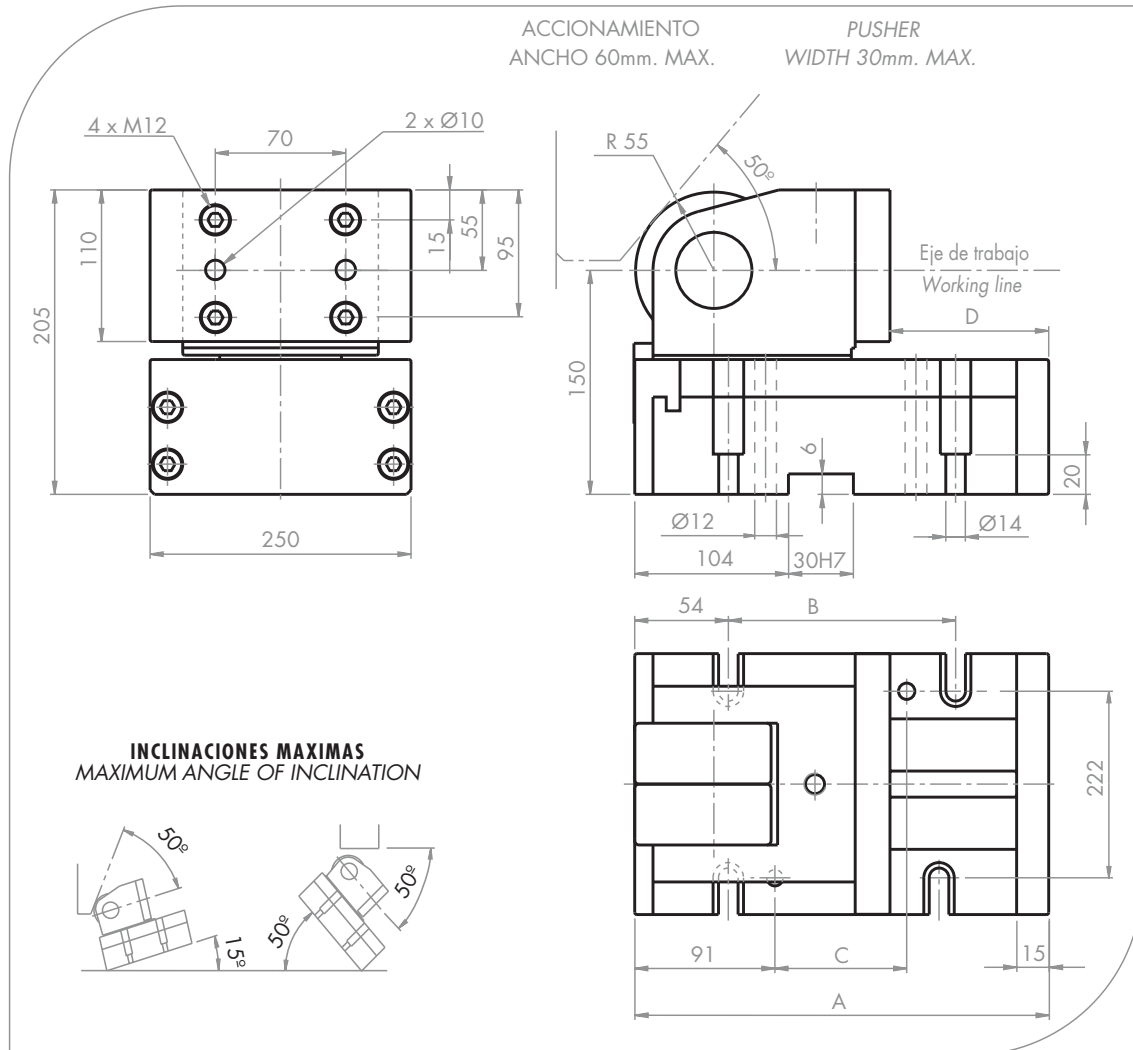

MODELO DE CARRO CAM MODEL	Carrera Stroke	A	B	C	D	Cilindro Spring
UCX-E.20.50	50	250	143	88	40	APF 500 x 63
UCX-E.20.80	80	280	173	118	70	APF 500 x 80
UCX-E.20.100	100	300	193	138	90	APF 500 x 100 - E1

MODELO DE CARRO CAM MODEL	Carrera máx. recomendada Recommended max. stroke	Fuerza máxima de punzonado (daN) Maximum puching force (daN)	Fuerza de retroceso (daN) Backward force (daN)
UCX-E.20.50	45	20000	500
UCX-E.20.80	72		
UCX-E.20.100	90		

### EJEMPLO DE PEDIDO / ORDER EXAMPLE

UCX-E 20 - 100

Modelo + Fuerza Tm.  
Model + Force Tm.

Tipo  
Type

Se recomienda una reserva del 10% de la carrera.  
Azol-Gas se reserva el derecho a efectuar cambios de diseño.

A 10% stroke lenght allowance is recommended.  
Azol-Gas keeps its right to make any desing modification.

# CARRO GCX.03

## GCX.03 ROLLER CAM

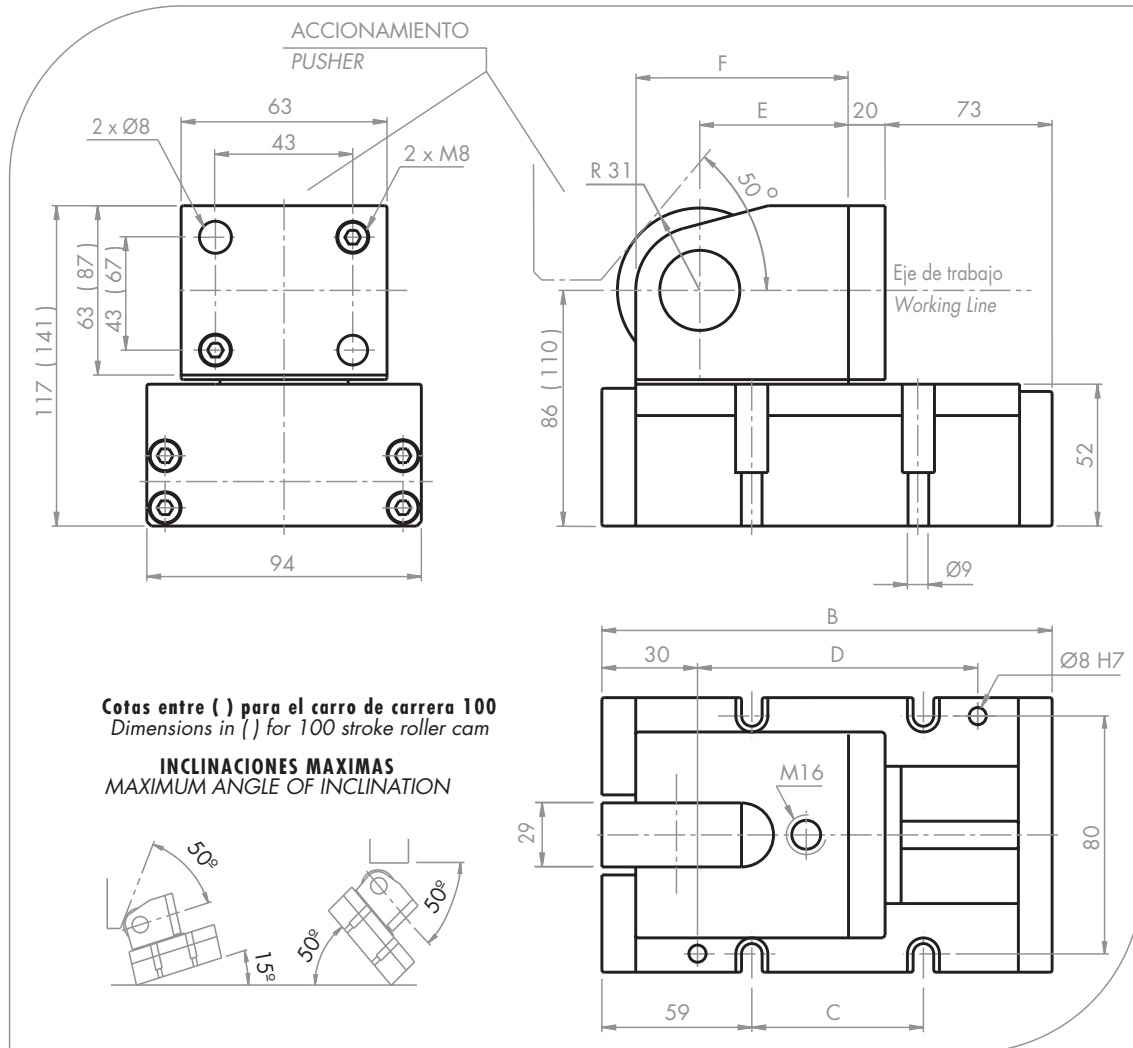

MODELO DE CARRO CAM MODEL	Carrera Stroke	B	C	D	E	F
GCX.03.50	50	190	76	134	66	85
GCX.03.80	80	220	106	164	96	115
GCX.03.100	100	260	146	204	136	155

MODELO DE CARRO CAM MODEL	Carrera máx. recomendada Recommended max. stroke	Fuerza máxima de punzonado (daN) Maximum puching force (daN)	Fuerza de retroceso (daN) Backward force (daN)
GCX.03.50	45	3000	200
GCX.03.80	72		
GCX.03.100	90		

### EJEMPLO DE PEDIDO / ORDER EXAMPLE

GCX 03 - 100

Modelo + Fuerza Tm.  
Model + Force Tm.

Tipo  
Type

Se recomienda una reserva del 10% de la carrera.  
Azol-Gas se reserva el derecho a efectuar cambios de diseño.

A 10% stroke length allowance is recommended.  
Azol-Gas keeps its right to make any desing modification.

# CARRO GCX.05 GCX.05 ROLLER CAM

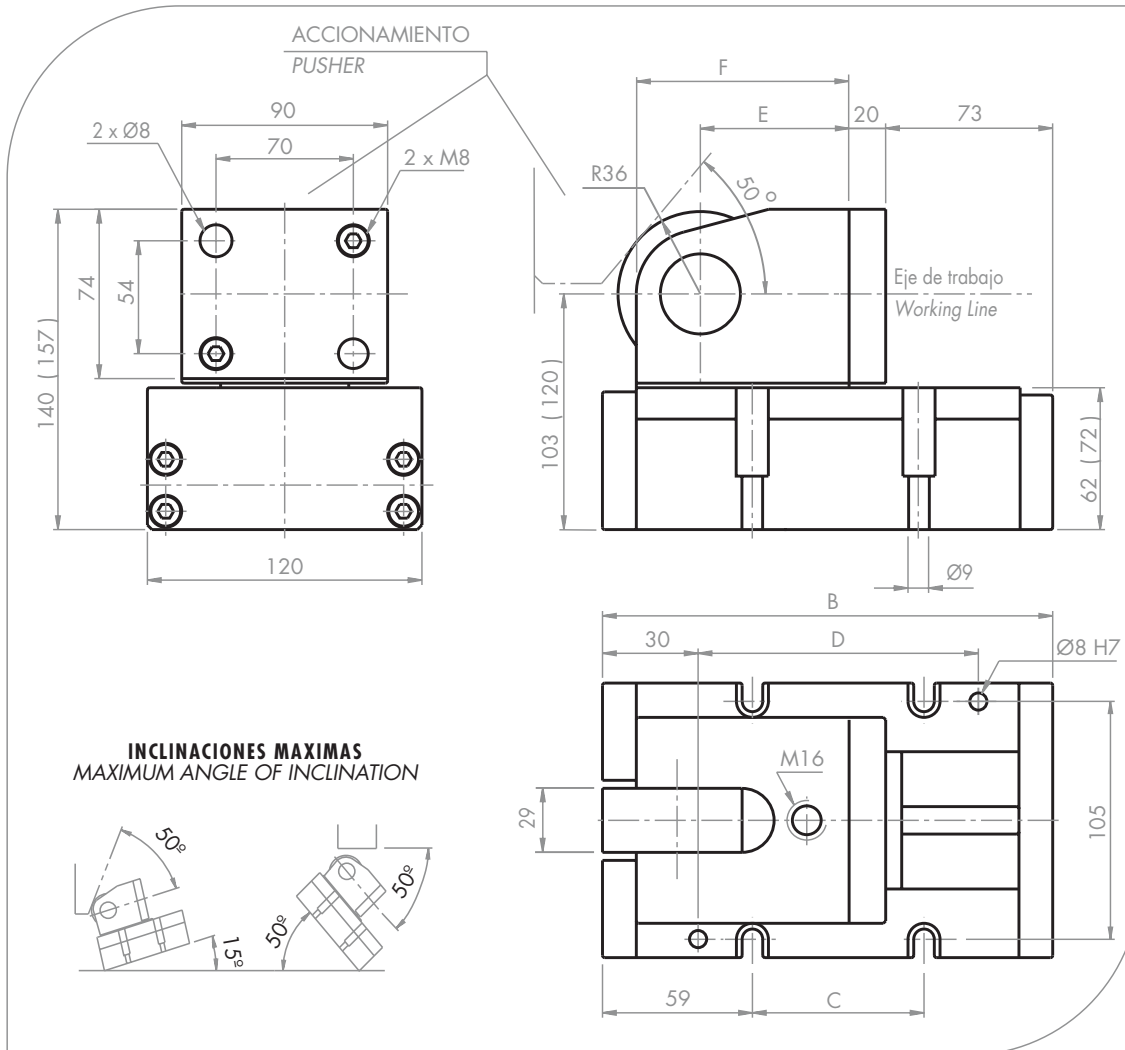

MODELO DE CARRO CAM MODEL	Carrera Stroke	B	C	D	E	F
<b>GCX.05.50</b>	50	190	76	134	61	85
<b>GCX.05.80</b>	80	220	106	164	115	91
<b>GCX.05.100</b>	100	260	146	204	155	131

MODELO DE CARRO CAM MODEL	Carrera máx. recomendada Recommended max. stroke	Fuerza máxima de punzonado (daN) Maximum pushing force (daN)	Fuerza de retroceso (daN) Backward force (daN)
<b>GCX.05.50</b>	45	5000	200
<b>GCX.05.80</b>	72		
<b>GCX.05.100</b>	90		

### EJEMPLO DE PEDIDO / ORDER EXAMPLE

**GCX 05 - 80**

Modelo  
Model + Fuerza Tm.  
Force Tm.

Tipo  
Type

Se recomienda una reserva del 10% de la carrera.  
Azol-Gas se reserva el derecho a efectuar cambios de diseño.

A 10% stroke length allowance is recommended.  
Azol-Gas keeps its right to make any desing modification.





# TABLAS DE CONVERSION CONVERSION CHARTS

## UNIDADES BASICAS / BASIC UNITS

MEDIDAS MEASURES	UNIDADES UNITS	SIMBOLO SIMBOL
Longitud / Length	Metro / Meter	m
Masa / Mass	Kilogramo / Kilogram	kg
Tiempo / Time	Segundo / Second	s
Fuerza / Force	Newton / Newton	N
Temperatura / Temperature	Kelvin / Kelvin	K
Presión / Pressure	Bar / Bar	bar

LONGITUD LENGTH	in	ft	yd	mm	m
1 in =	-	0.0833	0.0278	25.4	0.0254
1 ft =	12	-	0.333	304.8	0.3048
1 yd =	36	3	-	914.4	0.9144
1 mm =	0.03937	0.0033	0.00109	-	0.001
1 m =	39.37	3.2808	1.0936	1000	-

FUERZA FORCE	N	kp	pdf
1 N =	-	0.10197	0.22481
1 kp =	9.80665	-	2.20463
1 pdf =	4.4482	0.45359	-

TEMPERATURA TEMPERATURE	°K	°C	°F
1 °K =	-	K - 273.15	K 9/5 - 459.67
1 °C =	°C + 273.15	-	°C 9/5 + 32
1 °F =	5/9 (°F - 32) + 273.15	(°F - 32) x 5/9	-

VOLUMEN VOLUME	in <sup>3</sup>	US cuarto	imp. galón	ft <sup>3</sup>	US galón	l
1 in <sup>3</sup> =	-	0.0173	0.0036	0.00058	0.0043	0.0164
1 US cuarto =	57.75	-	0.2082	0.0334	0.25	0.9464
1 imp. galón =	277	4.8	-	0.1604	1.2	4.546
1 ft <sup>3</sup> =	1728	29.922	6.23	-	7.48	28.317
1 US galón =	231	4	0.8327	0.1337	-	3.785
1 l =	61.024	1.0567	0.220	0.0353	0.264	-

PRESION PRESSURE	in Hg	psi	atm	torr	mm Hg	bar	MPa	kg / cm <sup>2</sup>
1 in Hg =	-	0.491	0.0334	25.4	25.4	0.0339	0.00339	0.0345
1 psi =	2.036	-	0.0680	51.715	51.715	0.0689	0.00689	0.0703
1 atm =	29.921	14.696	-	760	760	1.0133	0.10133	1.0332
1 torr =	0.0394	0.0193	0.0013	-	1	0.0013	0.00013	0.00136
1 mm Hg =	0.0394	0.0193	0.0013	1	-	0.0013	0.00013	0.00136
1 bar =	19.53	14.504	0.987	749.87	749.87	-	0.1	1.020
1 MPa =	295.3	145.04	9.869	7498.7	7498.7	10	-	10.2
1 kg / cm <sup>2</sup> =	28.950	14.22	0.968	735.35	735.35	0.980	0.098	-